



programme

Signal + Noise

2005 *Festival of Video
and Sound*



SIGNAL+NOISE 2005 AND PACIFIC CINEMATHEQUE
PRESENT:

FROM L'ETRANGE FESTIVAL IN PARIS

THE HE(ART) OF SEX

"WOULD SEX BE AN ISSUE IF WE WEREN'T STILL LIVING IN A CHRISTIAN-DRIVEN SOCIETY? PROBABLY NOT, BUT IT IS - AND SCREENING FILMS ABOUT EXPLICIT SEX ALWAYS CAUSES A STIR, WHICH IS PROBABLY THE MAIN REASON WE DECIDED TO SCREEN A FLOAILEGIUM OF SEX MOVIES. SOME ARE HIGHLY GRAPHIC, OTHERS HIGHLY COMIC, OTHERS EXPERIMENTAL. EACH OF THE SHORT FILMS THAT ARE PART OF THIS PROGRAM CHALLENGES THE REPRESENTATION OF SEX AS SEEN IN 99% OF TRADITIONAL XXX PORN MOVIES."

- L'ETRANGE FESTIVAL

FOUNDED IN 1993, PARIS' L'ETRANGE FESTIVAL IS AN ANNUAL FILM FESTIVAL DEVOTED TO THE WORKS OF MAVERICK, MARGINAL AND INDEPENDENT-MINDED DIRECTORS FROM THE PAST AND PRESENT. CELEBRATING THE BIZARRE, THE SUBVERSIVE, THE TRULY OFFENSIVE, THE EXPERIMENTAL AND THE CULT, IT PROVIDES A PROVOCATIVE, PANORAMIC COUNTER-HISTORY OF THE CINEMA.



rought to you by **THE ART OF LOVING**

Art by Robin Bougie (www.cinemasewer.com)



Signal + Noise

2005 *Festival of Video
and Sound* 

Festival Mandate

Signal and Noise is a Vancouver based audio and video festival that takes place on an annual basis at Satellite Video Exchange Society/Video In Studios. This exciting festival features the work of local and international media artists and curators. The programs range from screenings, live sonic executions, and performance art.

Our festival's mandate is:

- To bring together diverse multi-media art practices together from local and international cities.
- To encourage and support local alternative and emerging artists to present their work in a widely received and attended venue with their peers from all over the world.
- To encourage collaborations from across Canada in order to create new communities and collectives.
- To facilitate the professional presentation of artists who are not typically programmed in mainstream venues and spaces.

About this year's festival...

Signal and Noise is Video In Studio's Fifth Annual celebration of evocative sonic executions and video creations by local and international multi media artists. Signal and Noise takes place this year from April 13-17, 2005 at Video In Studios, 1965 Main Street Vancouver, BC. Prepared to be immersed in a sea of sensory engagement and cognitive transformation! This year we are proud to co-present with the Pacific Cinematique, a special program from L'Estrange Festival in Paris, the carnal kickoff of Signal Noise Festival.

Welcome to Signal + Noise

This year we are exploding out of every orifice
Bringing you a maddening array of creative juices
Drink them up!

Allow your thirst
to be quenched by the spirit
of a multitude of diverse
and incredible people

RE:inventing relationships to sense your world
And destroying any notion
that there is only room in the spotlight for one
that we are not
all

in this together

I would especially like to thank all those magnanimous individuals who have volunteered their time and put their energy into helping make this years festival transcend the boundaries of all comprehension of what was once known as excellent!

Festival Coordinator

Velveeta Krisp

Let them sing it for you

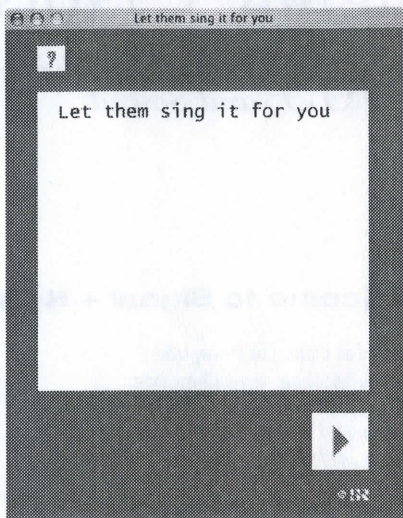

Erik Bünger

(presented every night) Interactive web art project, Berlin Germany
Through pop lyrics you learn to identify your own personal feelings of love, loneliness and joy with those of famous stars. Behind these public feelings there are often the desires of commercial powers such as record and film companies. Through "Let them sing it for you", you get the possibility of doing it the other way around. Instead of letting your vocabulary of feelings be dictated by famous voices, let the famous voices express your innermost thoughts.
www.sr.se/src/sing | www.erikbunger.com

Erik Bünger is a Swedish artist living in Berlin. He works exclusively with recontextualising and remixing media appropriated from already existing music and art, in performances, installations and web projects. He performs alone and together with his group Erik Bünger Ensemble.

This performance is made possible by The Arts Grants Committee of Sweden.

Diffusion

All sound work that is not performed live will be diffused.

Special Thanks to Barry Truax, Professor at the School for Communications and Contemporary Arts at Simon Fraser University, for arrangement of diffusion by SFU electroacoustic students. Thanks to Galen Elfert, Jonathan Herring, Phil Thomson, and Ben Wilson.

Environment One

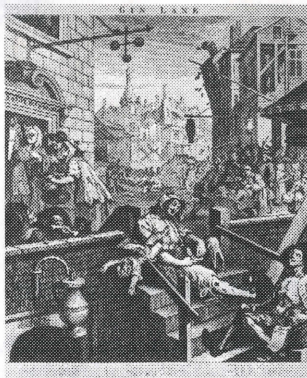

stones throw group

Back-space installation, Vancouver, BC
using audio, visual and olfactory elements to create a contemplative space, we are questioning our environments and how we interact with them, with found and prerecorded sounds and images of the natural world we create an artful space to lounge.

as a group of artists we spend our days mixing organic matter with synthesized and constructed realities. we work in video and sound. stones throw group consists of (but not always): a walker, cheryl hamilton, dj little d, j fisher, lj howes, lisa g

Festival Itinerary

April 13, 2005
SPECIAL PROGRAM CO-PRESENTATION WITH PACIFIC CINEMATIQUE
FESTIVAL L'ESTRANGE FROM PARIS PRESENTS
THE HE(ART) OF SEX
The festival begins April 13th with a kick off screening at 8pm at the Pacific Cinematique.

April 14th - April 17th
Video Program starts at 8pm
Followed by diffused and live audio performances at 10pm

Admission: \$6 video,
\$9 audio,
evening \$12,
festival pass \$35

April 14 2005

Videos 1 **Who Killed Target 1967?**
Angie Kwong

collection of accents
Fereshteh Toosi

Re-Performance: Freeing the Voice
Gale Allen

Out, Black + Proud in BC
April Sumter-Freutag

Prevention Tank
Jeremy Drummond

Il s'agit
Antoin De Bemels

Flooded Grass
Dandelion Wind Opaline Schlase

Moonshot
Meesoo Lee

Sounds 1 **Birthday Song**
Don Simmons & Ken Buera

3
Shon Anderson

Bombs 'r' Us
Nicole Sanches

at play amidst the
strangeness & charm
coin gutter

Free Bryan Adams
Pietro Sammarco

Singing the Dissected Laser Printer
Lee Hutzulak

The New Suitcase
Ken Roux

Who Killed Target 1967?

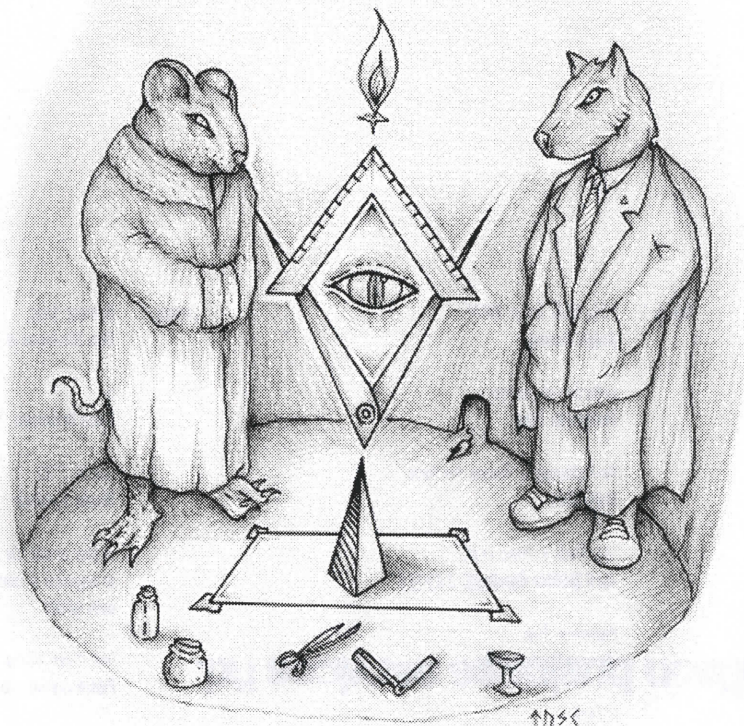

Angie Kwong

(11:12) Vancouver BC

"Who Killed Target 1967?" Is a sci-fi requiem for Jean-Luc Godard's star actress and muse, Anna Karina. Drawing on the myths of Frankenstein and Narcissus, the film sets out to deconstruct contemporary cinema's voyeuristic obsession with female beauty. A vengeful female scientist, outraged by Godard's victimization of Anna Karina, constructs a beautiful female robot to seduce and destroy lovers attracted solely by physical beauty. Conflict arises when the robot begins to outgrow her creator's intentions.

Angie Kwong was born in Hong Kong and currently lives and works in Vancouver. She received her BFA from Emily Carr Institute of Art and Design (Vancouver) in 2004. Her graduation film "Who Killed Target 1967?" has been exhibited locally and internationally. It received the Best Experimental Short Film Award in the 5th Melbourne Underground Film Festival as well as Best Directing and Best Film Awards in the 18th Annual National Student Film and Video Festival (Saskatchewan).



“What do you think this is,
Jerry Springer?”



COLLECTION OF ACCENTS

Fereshteh Toosi

(8:44) Pittsburgh, Pennsylvania, USA

Inspired by Saddam Hussein's use of body doubles during his career in Iraq, my collaborators and I visited Washington DC on Saddam's birthday while wearing masks depicting the Iraqi leader. Coincidentally, the search for the missing Saddam was featured on the front page of USA Today newspaper that same day.

Fereshteh Toosi is always looking for ways to ask strangers to share their stories and idiosyncrasies. She is interested in investigating stereotypes and typecast figures to investigate what people know and how they've come to feel comfortable with their own versions of truth.

RE-PERFORMANCE



Gale Allen

(03:15) Calgary, AB

R. POMMIER

"Re-Performance: Freeing the Voice" references an early work by Marina Abramovic in which she lay in a gallery screaming until her voice gave out. This piece takes the durational action of screaming from the private space of a gallery to the public space of the street.

Gale Allen is a video and performance artist based in Calgary. Her recent exhibitions include: Images (Toronto), Ladyfest (Toronto), The Reel Asian Film Festival (Toronto) and That 70's Ho (Vancouver).

Out, Black + Proud in BC

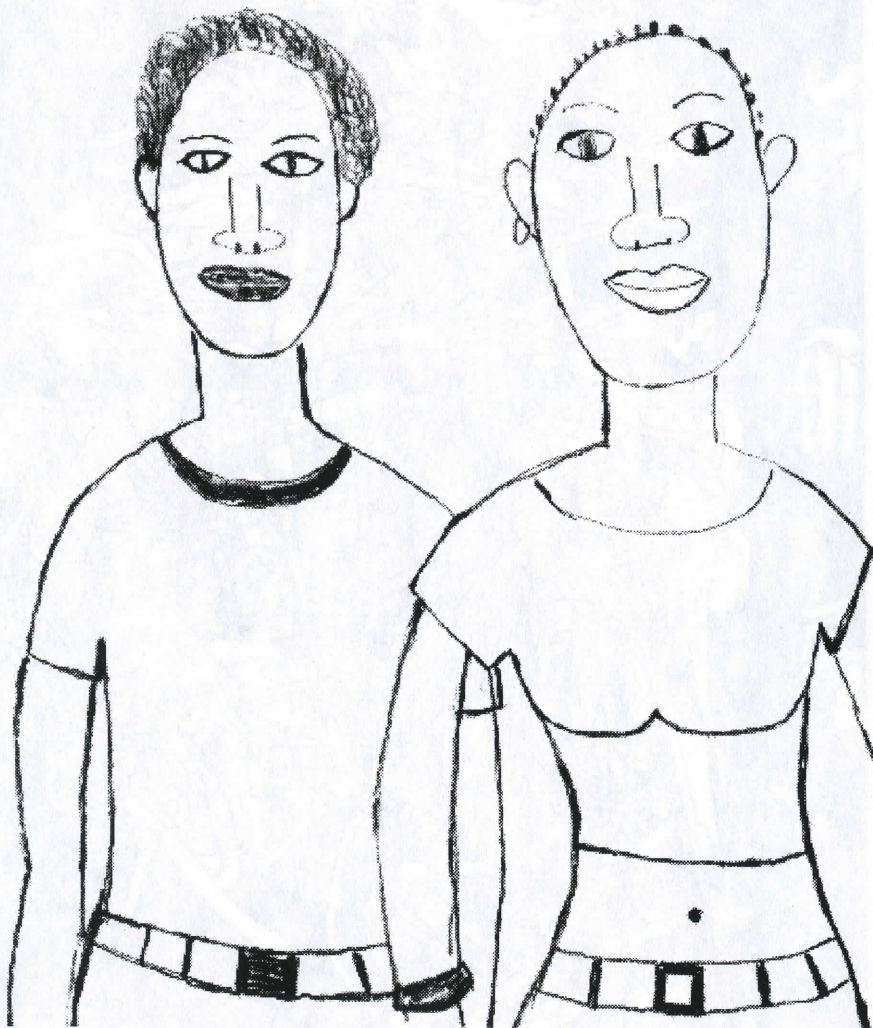

Liz Trueblood

April Sumter-Freitag

(13:15) Vancouver, BC

"Out, Black + Proud in BC": like chocolate, is bittersweet. It examines the relationship between desirability and undesirability, isolation and community, as it relates to being a GLBT British Columbian.

April Sumter-Freitag is a 7th generation black Canadian / first generation queer Canadian who loves film, television, video, women, flowers and a good story. "Out, Black + Proud in BC" is her first video and was inspired by her need to see herself and her community on the big screen to share their stories.

Prevention Tank

PREVENTION TANK



Jeremy Drummond

(06:00), Winnipeg, MB

Whether it is unwanted bacteria or chemical warfare, "Prevention Tank" represents the impossibility of avoiding contamination within one's environment.

In 2003, Jeremy Drummond received an MFA in Art Video from Syracuse University, New York. His video work has been exhibited internationally in festivals, galleries and museums. Currently, Jeremy is living in London where he teaches sessionally at the University of Western Ontario (New Media) and Fanshawe College (Printmaking/Digital Imaging). He is also Co-Director of the Forest City Gallery. His latest videotape, "Home Is Where You're Happy" (2003), is a thirty-minute collection of shorts dealing with masculinity, sexuality, violence, fear and anxiety in contemporary media culture.

Il s'agit



Antonin De Bemels

(04:15) Brussel, Belgium

Somehow, something is being told. There is at least one character involved, but there could be more. All there is to see is there to be seen. This is about.

Antonin De Bemels is a video and sound artist. Interested in experimental electronic music as well as contemporary dance and video art, his personal approach to videography is based on the representation of body movements and the dynamic relationship between sounds and images.

Flooded Grass



Dandelion Wind Opaline Schlase

(03:47) Vancouver, BC

I have been working on short stop-motion animation and music videos for the past couple of years. I always collaborate with avante-garde musician Szam Findlay on every video.

Moonshot

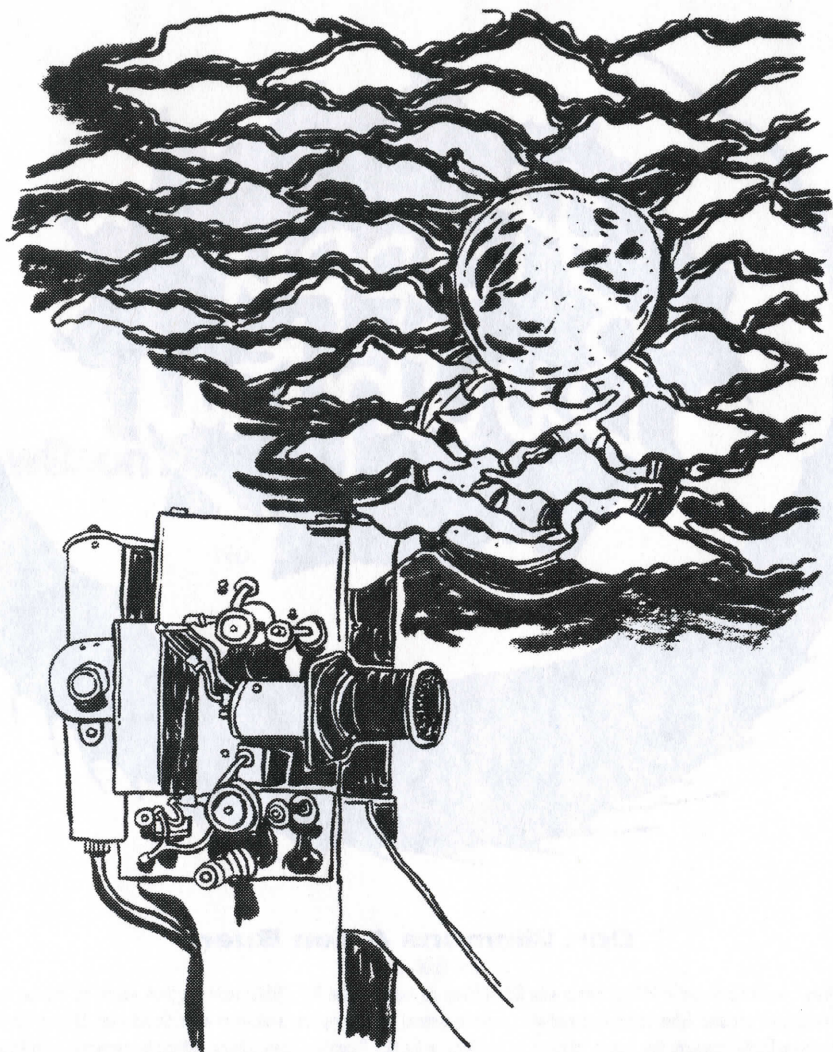

Meesoo Lee

(04:34) Vancouver, BC

It is a minimalist music video that was shot at the Pacific National Exhibition in the fall of 2004. The effects, except for the slow-motion, are all in-camera (variations in shutter speed). The ride is called "the wave swinger".

Meesoo Lee started making short videos using a camcorder and 2 VCRs, inspired by the DIY ethos of zines, "lo-fi" music and underground cinema. He is old enough to remember when music videos were something new and exciting, before the proliferation of VCRs, camcorders and neighborhood video stores... One of his favorite music videos dates back to his elementary school years: "You Might Think by The Cars". His work has been shown at the Western Front and Images Festival (Toronto).



Birthday Song



Don Simmons & Ken Buera

(pb) (5:00) Calgary, AB

"Art's Birthday" was first proposed in 1963 by French artist Robert Filliou. He suggested that 100,000,000 years ago, there was no art. But one day, on January 17th to be precise, Art was born. Filliou says it happened when someone dropped a dry sponge into a bucket of water. On Saturday, January 17th, 2004, Calgary based laptop group EMMAX produced this song in honour of Art's birthday, at the New Gallery in Calgary, Alberta. Utilizing live conversations in the gallery, phone messages, and streamed audio from the internet, EMMAX remixed the ambience of local celebration.

Don Simmons is a conceptual artist based in Calgary, Alberta. Recently, he completed his MFA degree at the Nova Scotia College of Art and Design in Fine and Media Arts. In the past, he studied art history in Italy while completing his diploma in Drawing and Painting at the Ontario College of Art and Design. Simmons has participated in exhibitions across Canada and the US, with forthcoming exhibitions at the Walter Phillips Gallery (Banff) curated by Jim Drobnick, the Western Front (Vancouver) curated by Victoria Singh & Velveeta Krisp, as well as the Truck Gallery and EMMEDIA in Calgary. Simmons' work usually takes the form of robotics, electronics, audio, installation or performance. He is currently on faculty at the Alberta College of Art and Design in their Media Arts and Digital Technologies Department.

3

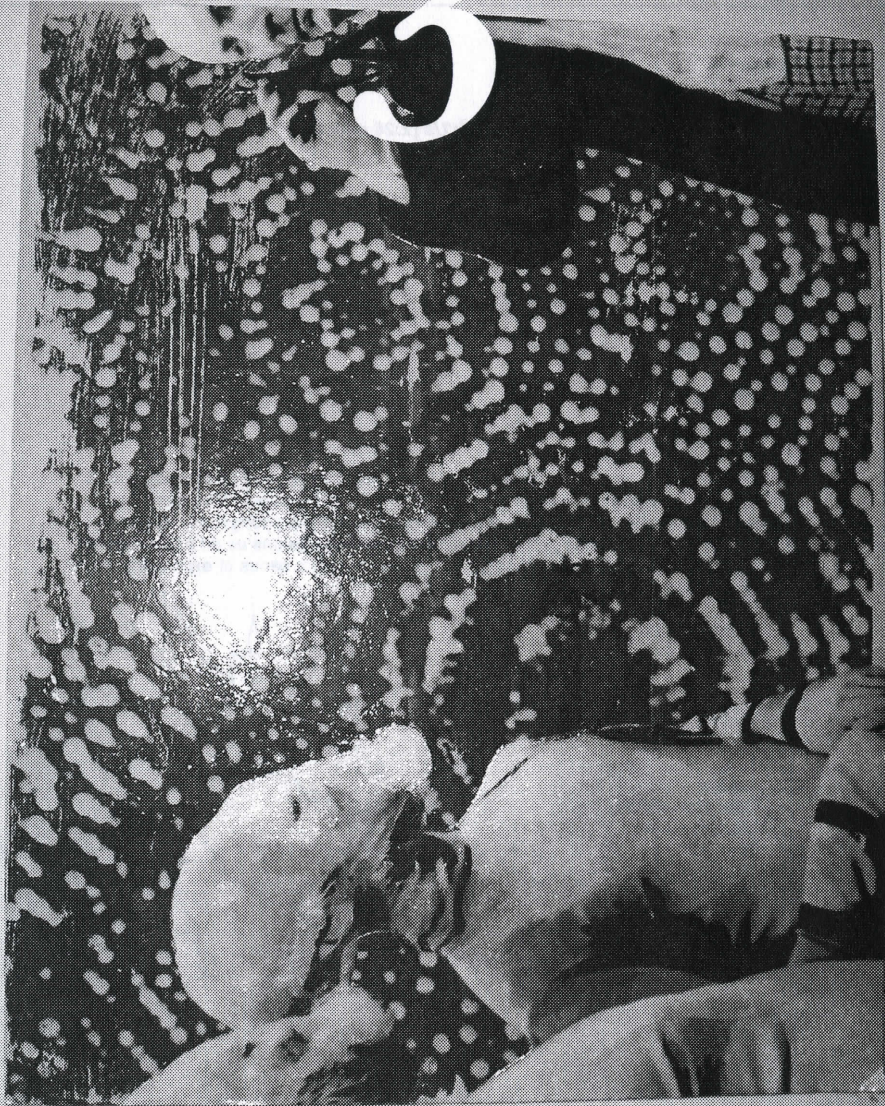

Shon Anderson

(pb) (2:31) Calgary, AB

I was born in Calgary Alberta. I have been using computers to make music for a few years. I am enthused by recent developments in the business of music. My work has been an exploration of experimental and popular elements. These may serve to highlight one another, today when these issues are so prevalent. Digital technology serves as a reminder that the world is changing for good, again.

Bombs 'r' Us

Bombs'r'Us (2:26 minutes)

Panic

Fierce fighting

Casualties occurred during clashes

Heavy outbreak of fighting

Among the dead

The latest violence

In the safe realm that we live in these terms seem exotic and of far away places. What is our knowledge of armed conflict on the grand scale of things unless we are directly affected by battle or military campaigns? As youngsters, playing soldier was an exciting game that involved vocal explosions as an expression of battle. The sound piece, "Bombs'r'Us", is very simply a series of explosions made by the human voice.

Nicole Sanches
August 2004

Sound Design
Paul Bennett

Voices
Ross Kakuschke
Vincent Parker
Tom Schulz
Paul Bennett
Nicole Sanches

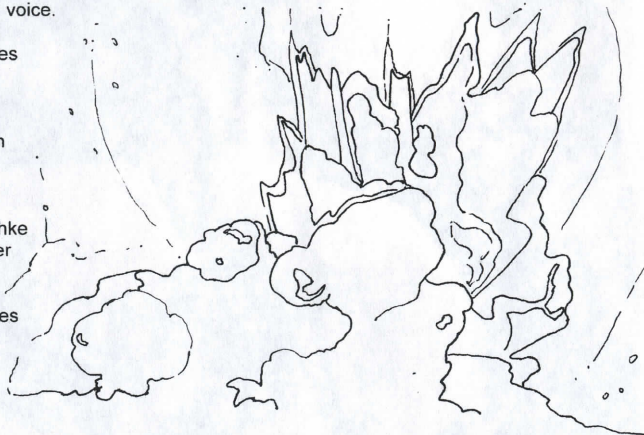

Nicole Sanches

(pb) (2:26) Vancouver, BC

Nicole Sanches is a visual artist who maintains a studio practice in Vancouver, British Columbia. Her work examines mediated experiences and altered states while questioning the impact of technological advances on our bodies. She has exhibited in Canada and the United States.

at play amidst the strangeness & charm

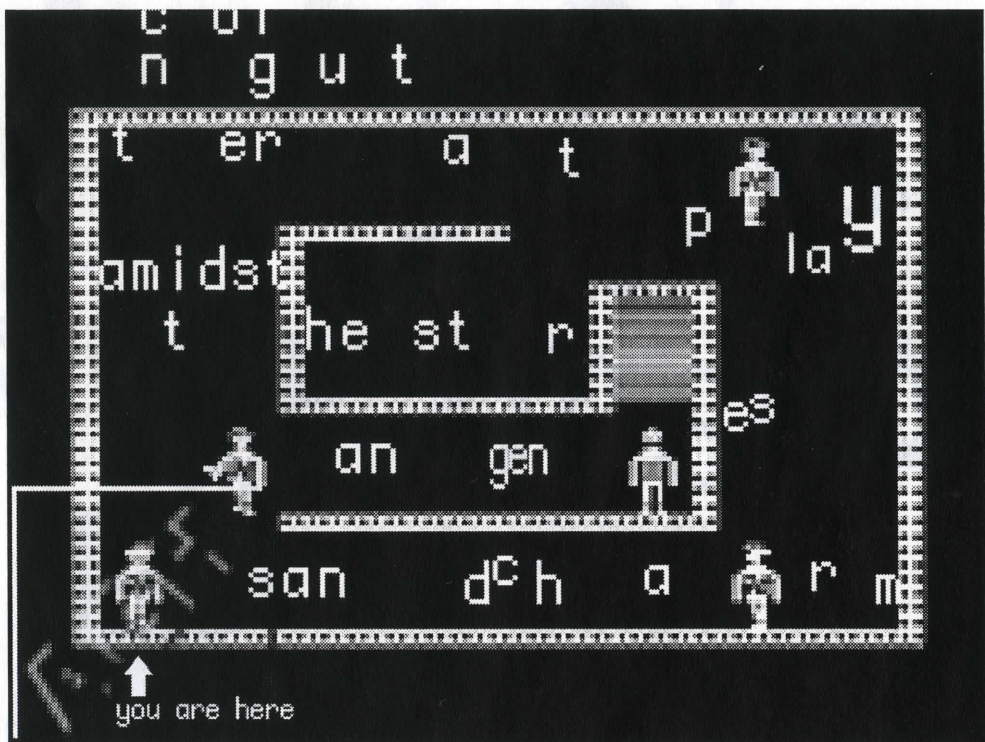

coin gutter

(pb) (5:55) Vancouver, BC

this track is from our upcoming release 'origin and destination' and is a hidden track. or will be a hidden track. it is a mash of the other three tracks that make up the disk. we aren't saying any more on the subject.

coin gutter formed in 2000. since then they have had 5 releases, including one on no type out of montreal. they have toured canada twice, played mutek and signal and noise 2003. coin gutter are sort of like your alarm clock. then again, maybe they aren't.

Free Bryan Adams

Thurs. Apr. 14. 05
10pm

Video In
1965 Main Street
Vancouver, BC



Part of Signal + Noise 2005
<http://signalandnoise.ca/>

Pietro Sammarco

(Live) (10:00) Vancouver, BC

I will free Bryan Adams' songs from their pop shackles by playing them sincerely. NOT IRONICALLY. I will feel them, fill them and set them free, the same way an obsessed fan will repeat his lyrics over and over until they are truly holy.

I'm a graduate of Emily Carr, part of the collective called Norma, part of the band "They Shoot Horses, Don't They?" I do many, many different things and hate writing artist bios, especially fifty-word ones. Visit <http://www.geocities.com/pietrosammarco> for more! I don't have a cd of this piece, only photos. Want to see them?

Singing Dissected Laser Printer
Disc 3

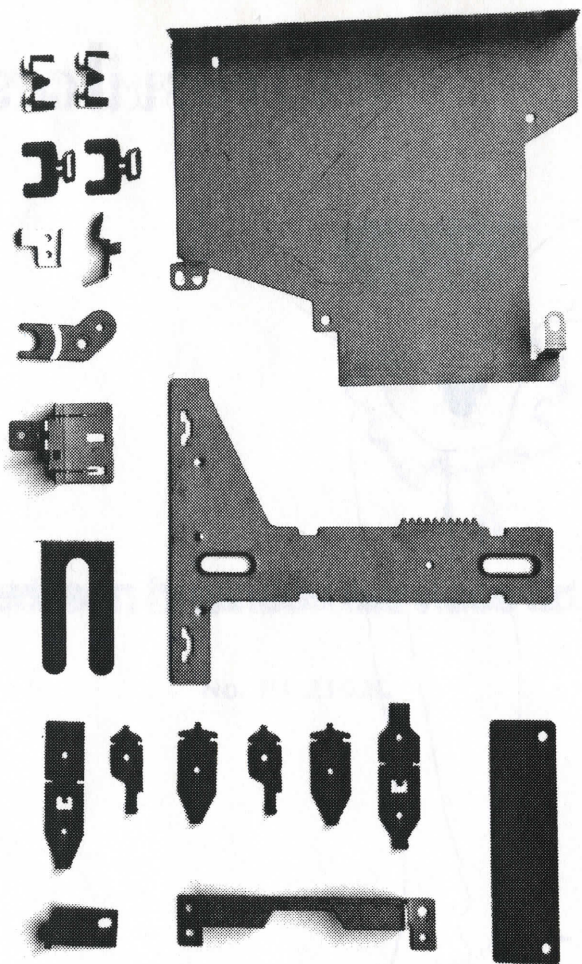

01 2.0oz metal bristles	0.02
02 2.0oz metal bristles	0.02
03 5/16" flat rubber metal x pulser rgt	2.27
04 Heavy top metal metal bristles	2.95
05 Plastic gear	2.52
06 Peltling	0.10
07 1/2" x 1/2" tang	0.10
08 milled tang	0.03
09 1/2" x 1/2" tang	0.03
10 1/2" x 1/2" tang	0.03
11 1/2" x 1/2" tang	0.03
12 1/2" x 1/2" tang	0.03
13 1/2" x 1/2" tang	0.03
14 1/2" x 1/2" tang	0.03
15 mid epoxy roller buzz	0.08
16 mid epoxy roller buzz	0.08
17 mid epoxy roller buzz	0.08
18 rubber gong roller buzz	0.07
19 low gong roller buzz	0.07
20 low gong roller buzz	0.11
21 switch roller x latent thunks	0.11
22 3/4" x 1/2" x 1/2" ratchet	2.24
23 1/2" x 1/2" ratchet	0.26
24 metal/metal scrape	0.14
25 metal/metal scrape	0.38
26 metal/metal scrape	0.25
27 shiny zinc panel	0.17
28 shiny zinc panel	0.27
29 low rubber roller rhytm	2.47
30 1/2" x 1/2" rubber roller surge	1.46
31 1/2" x 1/2" rubber roller surge	2.23
32 1/2" x 1/2" rubber roller surge	2.22
33 1/2" x 1/2" rubber roller surge	2.28
34 1/2" x 1/2" rubber roller surge	0.12
35 low roller roller scrape	0.10
36 dry roller roller scrape	0.08
37 mid low roller scrape	0.10
38 mid low roller scrape	0.10
39 mid low roller scrape	0.10
40 empty roller scrape	0.06
41 mid low roller scrape	0.05
42 empty roller scrape	0.05
43 mid low roller scrape	0.05
44 mid low roller scrape	0.05
45 1/2" x 1/2" roller scrape	0.09
46 1/2" x 1/2" roller scrape	0.09
47 high low roller scrape	0.07
48 high low roller scrape	0.09
49 high low roller scrape	0.09
50 low low roller scrape	0.11
51 low low roller scrape	0.10
52 low low roller scrape	0.10
53 dry metal roller scrape	0.19
54 dry metal roller scrape	0.12
55 dry metal roller scrape	0.12
56 dry metal roller scrape	0.08
57 smooth blue block	0.15
58 smooth blue block	0.17
59 smooth blue block	0.17
60 smooth blue block	0.13
61 dry metal scrape	0.13
62 dry metal scrape	0.14
63 dry metal scrape	0.12
64 reaction steel roller scrape	0.18
65 reaction steel roller scrape	0.20
66 reaction steel roller scrape	0.21
67 low rubber roller scrape	0.12
68 1/2" x 1/2" rubber roller scrape	0.25
69 1/2" x 1/2" rubber roller scrape	0.27
70 1/2" x 1/2" rubber roller scrape	0.27
71 1/2" x 1/2" rubber roller scrape	0.28
72 1/2" x 1/2" rubber roller scrape	0.14
73 1/2" x 1/2" rubber roller scrape	0.25
74 1/2" x 1/2" rubber roller scrape	0.19
75 1/2" x 1/2" rubber roller scrape	0.14
76 1/2" x 1/2" rubber roller scrape	0.11
77 1/2" x 1/2" rubber roller scrape	0.13
78 1/2" x 1/2" rubber roller scrape	0.07
79 1/2" x 1/2" rubber roller scrape	0.06
80 1/2" x 1/2" rubber roller scrape	0.11
81 1/2" x 1/2" rubber roller scrape	0.13
82 1/2" x 1/2" rubber roller scrape	0.13
83 1/2" x 1/2" rubber roller scrape	0.09
84 1/2" x 1/2" rubber roller scrape	0.09
85 1/2" x 1/2" rubber roller scrape	0.09
86 1/2" x 1/2" rubber roller scrape	0.12
87 1/2" x 1/2" rubber roller scrape	0.06
88 1/2" x 1/2" rubber roller scrape	0.07
89 1/2" x 1/2" rubber roller scrape	0.08
90 1/2" x 1/2" rubber roller scrape	0.08
91 1/2" x 1/2" rubber roller scrape	0.08
92 1/2" x 1/2" rubber roller scrape	0.11
93 1/2" x 1/2" rubber roller scrape	0.07
94 1/2" x 1/2" rubber roller scrape	0.09
95 1/2" x 1/2" rubber roller scrape	0.13
96 1/2" x 1/2" rubber roller scrape	0.13
97 1/2" x 1/2" rubber roller scrape	0.04
98 1/2" x 1/2" rubber roller scrape	0.04
99 1/2" x 1/2" rubber roller scrape	1.12

LEE HUTZULAK PETER LE

SINGING THE DISSECTED LASER PRINTER

Lee Hutzulak

(Live) (20:00) Vancouver BC

A broken office laser printer is carefully dissected into its hundreds of component pieces. Using only these pieces, a work surface and a recording studio, the dissected printer is bowed, rolled, knocked, shuffled, rattled, etc. Over 2 hours of recorded raw performance are meticulously edited, separated into individual events and burned as 3 CDs, each comprised of 99 tracks. The tracks range in length from 4 seconds (single knocks / taps / thumps) to 3 minutes (rattling / scraping / bowing). The selected events from these 297 individual pieces are then placed into a 16 track mixer / hard disc recorder on a timeline forming an approximate but flexible composition. In addition, the prepared CDs are accessed and manipulated in portable CD players. Although a few external electronics are also utilized to extend the sounds, the main focus is on the pure unprocessed tones coaxed from the printer parts themselves. To this end, a number of the actual printer parts are "played" acoustically in the performance. With a nimble touch the resulting music is rich in tone and texture, from ranging a last gasp death rattle to a purgatory of sustained monotony, from a sonorous piece to a miniature factory in full production.

Lee Hutzulak is a musician and recording artist working in and around Vancouver since 2000. For info on past, present and upcoming projects including photos, art and MP3s, visit www.leehutzulak.com

The new suitcase

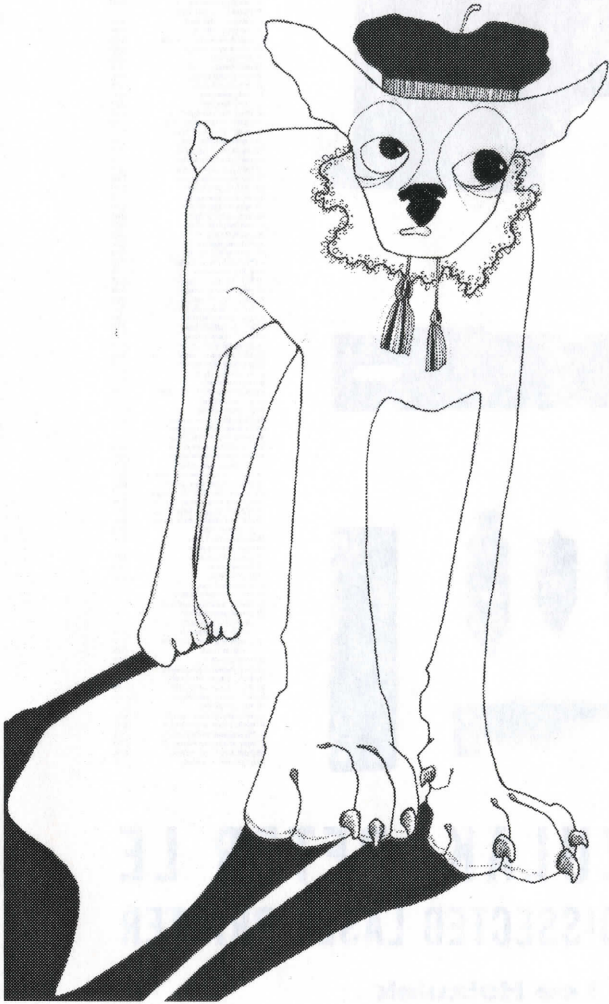

drawings by magphild vs winsnes

Ken Roux

(Live) (30:00) Vancouver, BC

"The New Suitcase" is a free-standing feedback instrument controlled by a patch bay. It contains its own speakers, microphones, and means of amplification. An acoustic laptop.

Ken Roux makes audio creations that address issues in electronic music and other contraptions just for the heck of it.

April 15 2005

Some colour?

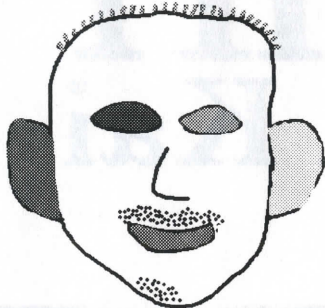

Juha Valkeapää

Voice performance, Helsinki, Finland

A customer sits at my barber's chair, I cover her/his eyes, lift her/him a little bit from the ground, and voice her/his portrait with her/his first name and a prop (bells, fruit, cans etc) s/he has selected from the table.

Juha Valkeapää is a vocal artist since 1992. Solo & group works in the areas of performance art, theatre, music & dance. Visit his site at the following URL www.nbl.fi/juha.valkeapaa

The Department of Media and Culture,
Ministry for Foreign Affairs, Finland - Embassy of Finland, Ottawa ON.

Also performed on this day is "The Safety Patrol" see page 39 for details.

Videos 2 A Girl Named Kai
Kai Ling Xue

Top Floor Parking
mda hates

A Miracle
Daniel Barrow

Strongest Man
Jeremy Bailey

Graphic Material
Evan Tapper

A Safer America
Jeremy Drummond

Bush Wact
Mike Maryniuk

Get out of my fucking room
Julian Hou

You Can Call Me Anything You Want
Helena Schultheis
& Azra Svedruzi

The Clearing
Dandilion Wind Opaline Schlase

Cats and Pants
Jennifer Matotek

Sounds 2 Awkward Organs
Dirk Adams

Wake (excerpt)
Mortalmanifest, Oren Ben Yosef

Perf
Brandon Blommaert

Square 'Em Up
Chris Lowe

Racket
Christian Nicolay

The Inlect of Ventilation
Derek Champion

Gloss
Patrick Valiquet

Holzkopf

A Girl Named Kai



Kai Ling Xue

(10:00) Vancouver, BC

Using Super-8 and 16mm footage, filmmaker Kai Ling Xue opens her personal diary to us to reveal a journey about relationships, self-discovery, passion, secrets and dreams.

Kai Ling Xue was born in Taiwan and moved to Vancouver in 1997 to pursue her dream as an interdisciplinary artist. Her work explores women's issues, race and sexuality.

Top Floor Parking

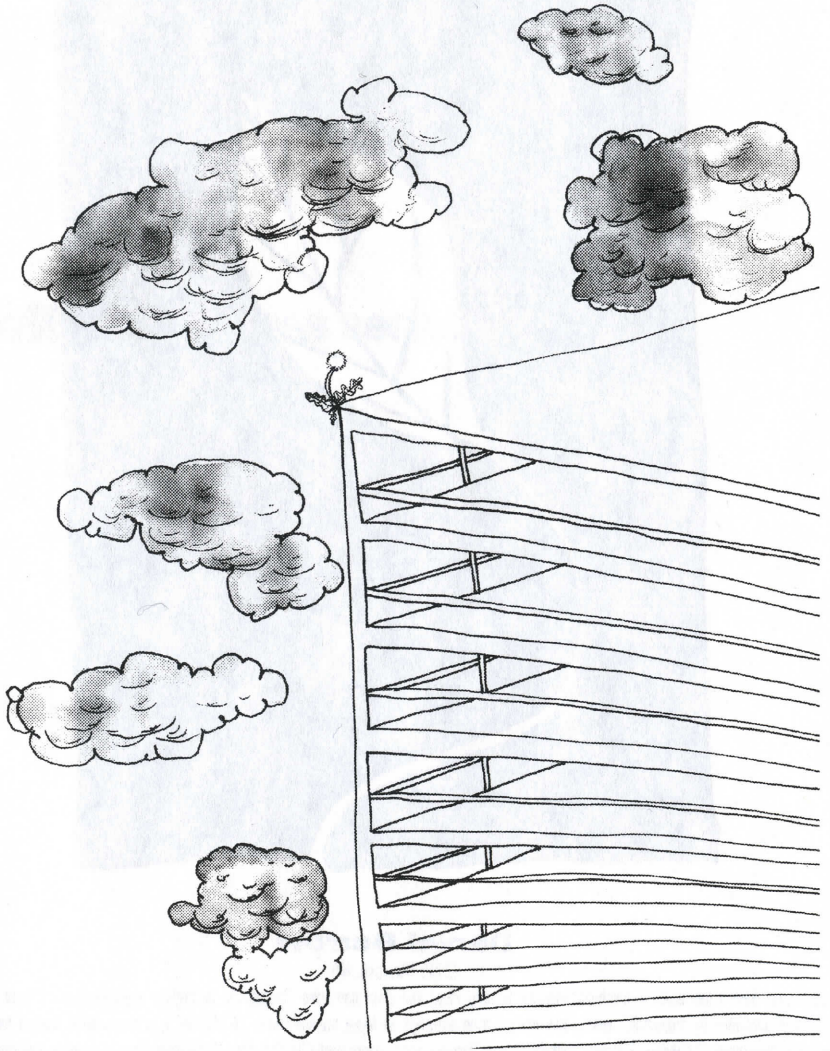

mda hates

(5:00) Victoria, BC

A transitory meditation on the art of just being happy just being. / mda hates talking about himself. Less talk = more action. More action = more art.

A Miracle



Daniel Barrow

(2:52) Winnipeg, MB

Since 1993, Daniel Barrow has used an overhead projector to relay ideas and short narratives. Specifically, he creates and adapts comic book narratives to a "manual" form of animation by projecting, layering and manipulating drawings on Mylar transparencies. "A Miracle" is a music video created for Toronto-based "gay church folk" musicians, The Hidden Cameras, that documents Barrow's performance methods. The story of the video features a young boy lying in bed, using the light of the moon to make shadow puppets on his bedroom walls. While experimenting with forms, he summons the spirit of a huge fruity, bird-like creature with the silhouette of an owl, and the feathers of an ostrich. The creature has a brief, sensual exchange with the boy before swallowing him whole and then regurgitating, twisting and compressing him into a gizzard-shaped ball.

Daniel Barrow is a media artist living in Winnipeg. He exhibits widely in Canada and abroad. Much of Daniel's work aims to collide the popular imagery from childhood and prepubescent adolescence with residual feelings of backwardness, innocence, joy, shame and separation. In doing so he attempts a return to a former and less complex experience of media stimulus.

Strongest Man



Jeremy Bailey

(4:33) Toronto, ON

I try and hold a camera at arm's length. Things get sexy.

Jeremy Bailey completed his undergraduate work at the University of Toronto. He is currently pursuing his MFA in Video Art at Syracuse University where he programs for SPARKVIDEO, a local and international video series. He is a founding member of the 640480 Collective.

Graphic Material



Evan Tapper

(2:00) Toronto, ON

Finding a discarded Manga comic leads me to confront my limitations in liberating the hero (and myself) from a misogynist context.

Evan Tapper was born in Winnipeg and is currently based in Toronto. He received a BFA from the University of Manitoba and an MFA from Carnegie Mellon University in Pittsburgh. His multimedia work has been exhibited throughout Canada, the United States, Europe, and Japan.

A Safer America

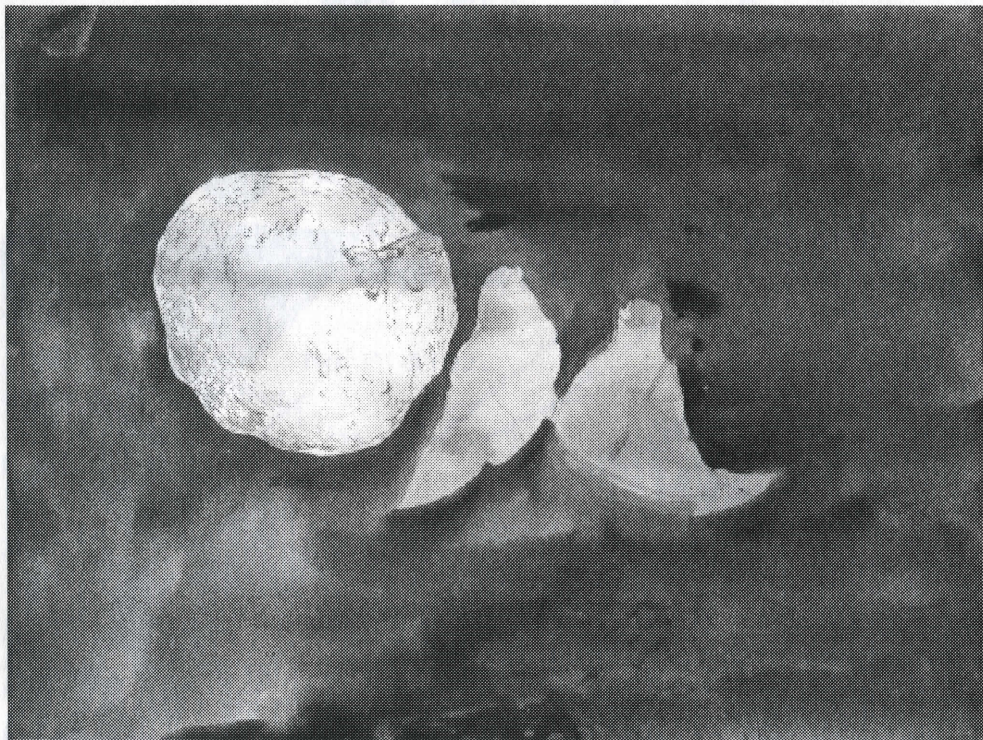

Jeremy Drummond

(5:00) Winnipeg, MN

Shot in New York City, this videotape deals with media-influenced anxiety and the commodification of fear.

In 2003, Jeremy Drummond received an MFA in Art Video from Syracuse University, New York. His video work has been exhibited internationally in festivals, galleries and museums. Currently, Jeremy is living in London where he teaches sessionally at the University of Western Ontario (New Media) and Fanshawe College (Printmaking/Digital Imaging). He is also Co-Director of the Forest City Gallery. His latest videotape, "Home Is Where You're Happy" (2003), is a thirty-minute collection of shorts dealing with masculinity, sexuality, violence, fear and anxiety in contemporary media culture.

Bush Wact

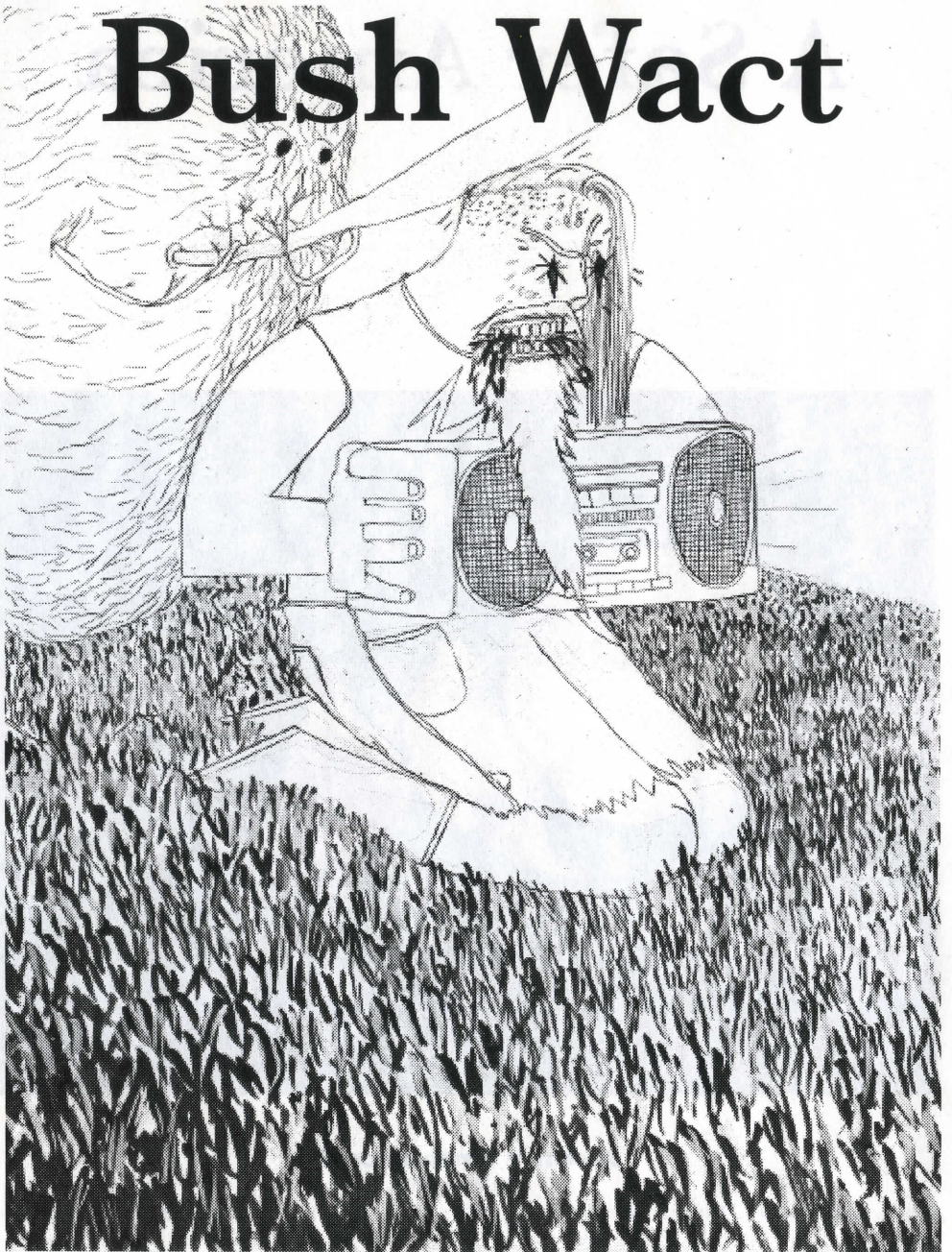

Mike Maryniuk

(2:50) Winnipeg, MB

"Bush Wact" is an anti-war film collage with scratch animation over the face of George W. Bush.

Mike likes to fuck shit up. Mike doesn't like W. Mike scratched in his face.

Get out of my fucking room

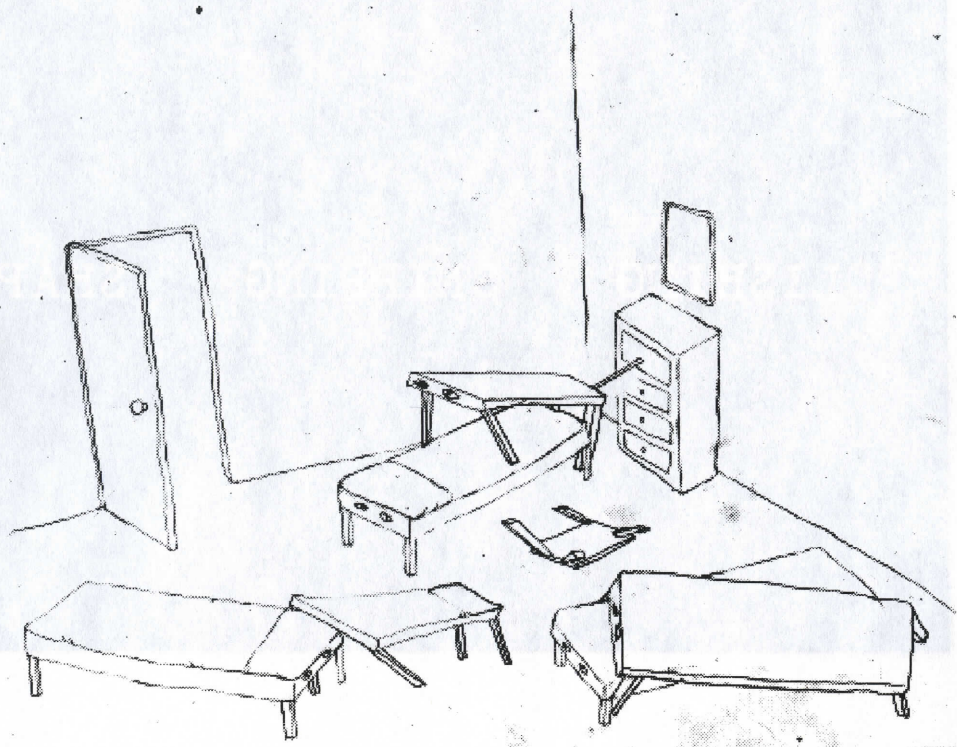

Julian Hou

(5:00), Vancouver, BC

This video projection is composed of a series of short clips taken from my bedroom over a month long period, superimposed over the clips is the statement.

Julian Hou is from Vancouver and primarily works with video and text. He is a student at Simon Fraser University.

You Can Call Me Anything You Want

POLISHING

SNIPPING

SHAPI

Helena Schultheis & Azra Svedruzi

(6:20) Zagreb, Croatia

The work is composed of visual and textual elements, which are intertwined. However, since the text is treated as conscious, and the visuals as a subconscious way of story-telling they are also forced to oppose each other. In this attempt to explain each other, a dialogue is created finding its source in female handwriting.

Schultheis: born 1972, Zagreb, Croatia. Education: Art History at the Art Academy in Zagreb, Croatia. Painting at Institut-Holland, Amsterdam. Works as Assistant Professor at Design University. Last Festival appearance in 2004. New York, U.S.A. Recent Croatian Video and Experimental Film Selection, Millennium Film Workshop Inc.

Svedruzi: Born 1969, Croatia. Education: Art History at the Art Academy in Zagreb, Croatia. Last Festival appearance in 2004. New York, U.S.A. Recent Croatian Video and Experimental Film Selection, Millennium Film Workshop Inc.

The Clearing

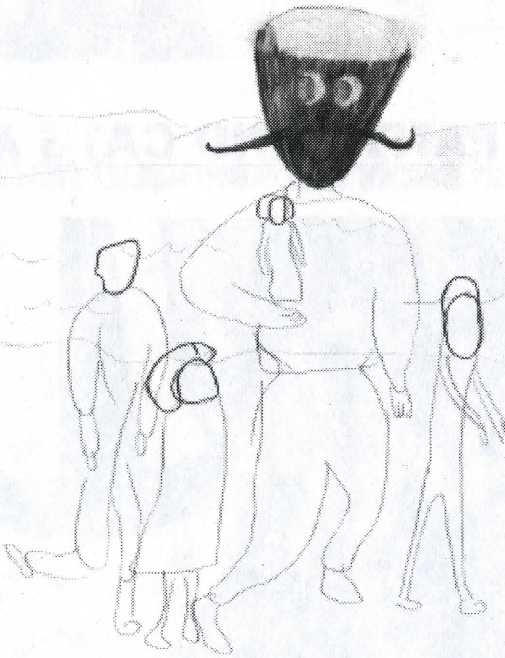

Dandelion Wind Opaline Schlase

(3:41) Vancouver, BC

I have been working on short stop-motion animation and music videos for the past couple of years. I always collaborate with avante-garde musician Szam Findlay on every video.

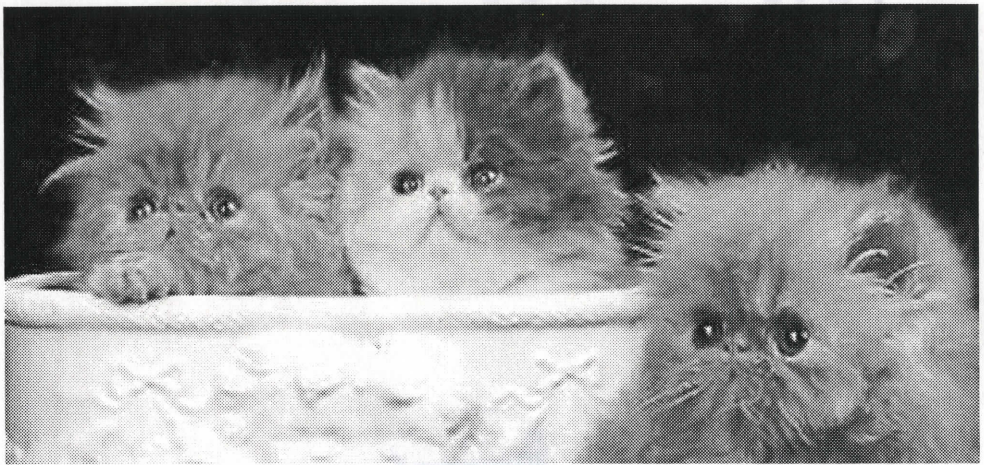

CATS AND PANTS AND CATS AND PA



Jennifer Matotek

(1:00) Oakville ON

Cats and Pants: Better experienced than understood.

Jennifer Matotek is a multidisciplinary artist based in Oakville, Ontario, whose videos, sculptures, performances, drawings and digital images have been shown in many group exhibitions since her graduation from the University of Toronto and Sheridan College of Art's Art History programme in 2001.

Awkward Organs

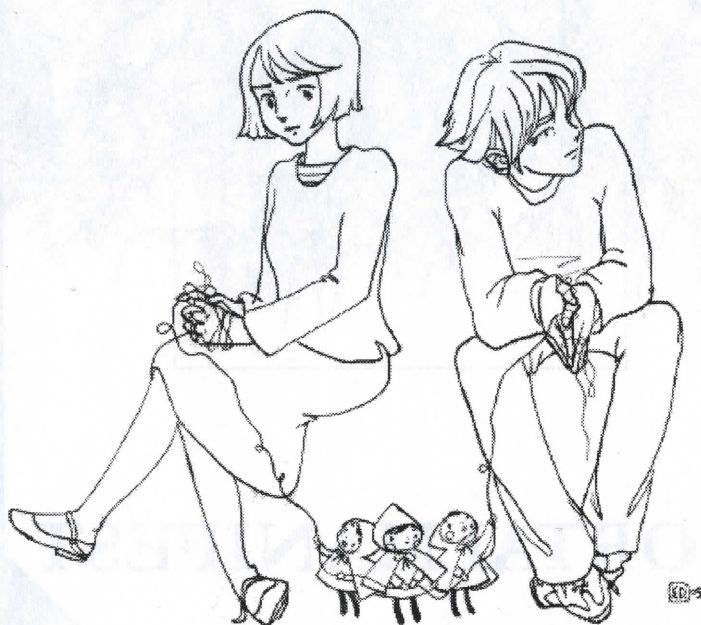

Dirk Adams

(pb) (6:02) Roslindale, MA, USA

Awkward Organs takes as source material a series of vocalizations. Much of my work involves the use and limits of language to describe the world, one's emotions, the self. With this piece, I explore the possibilities of creating meaning and narrative with non-language utterances.

In much of my audio work, the merging of physical and auditory experience remains one of my central areas of fascination. In multi-channel and installation work, I explore the possibilities of spatializing sound to activate the architecture of the exhibition space. Through sound walks, I aim to create a very personal relationship for the solitary listener wherein a heightened awareness of his or her surroundings is evoked by the content of the audio score.

Wake (excerpt)

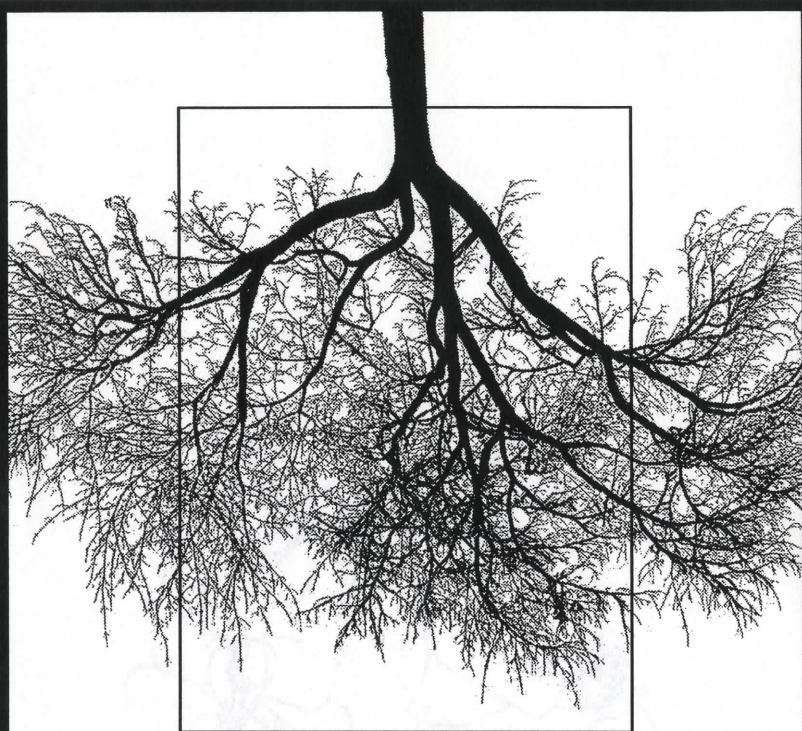

MORTALMANIFEST

"Mortalmanifest" Oren Ben Yosef

(pb) (10:10) Kfar Saba, Israel

Imposing fear, Wake, as its name suggests, is a 53 minute ceremonial audio work that follows ten stages of its bleak funeral, from gathering to scattering. The music itself, besides the ceremonial repeating bells, is not really music, only the traces of one long forgotten tune.

Oren is also known as Mortalmanifest, an act that started its way from harsh industrial beats and found the path of scorched and ceremonial ambience. MortalManifest creates bleak sounds and textures that feel the places where music once was.

Perf



Brandon Blommaert

(pb) (13:02) Calgary, AB

The CDR is mainly a compilation of sounds that were created mainly to accompany a number of short animations which were made at the beginning of 2004. These sounds, whether they were used or not, have been further expanded and altered into short compositions.

Brandon Blommaert is a Calgary based artist. His field of interest shifts from animation, printmaking, drawing, and sound design, etc.

SQUARE 'EM UP

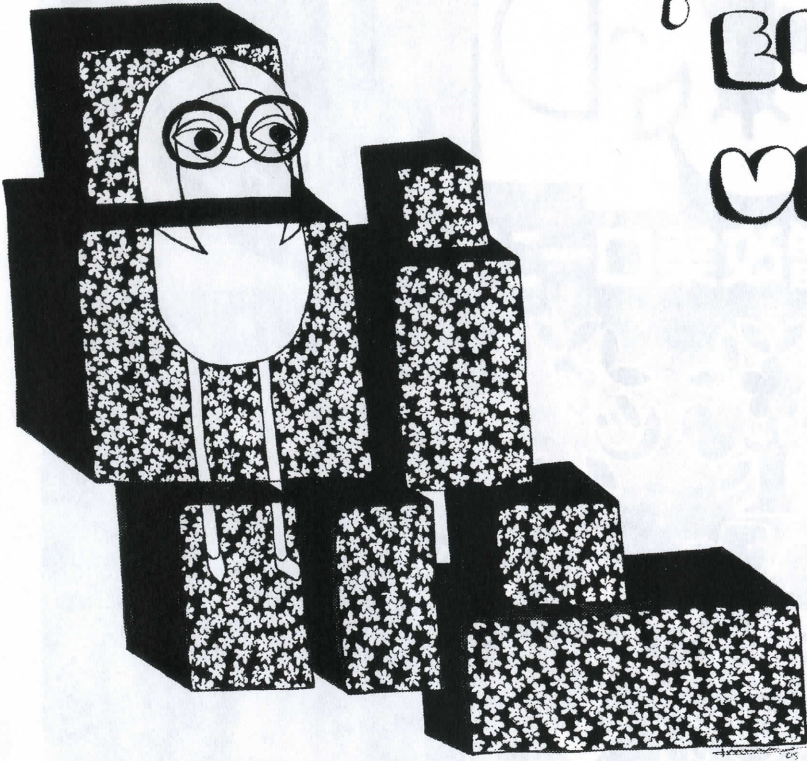

Chris Lowe

(pb) (5:52) Quispamsis, NB

An experimental documentary exploring a young man's birthright to call a square dance. Based on a true story.

Chris Lowe was born in Saint John NB, 1976. Bachelor of Fine Arts from NSCAD 2003. Worked in Media Arts Department, NSCAD. Taught ESL in South Korea. Taught Grades 9 and 10 Art at St. Malachy's Memorial High School in Saint John. Executive Committee member, Continental Drift Film Fest. Inc.

Racket

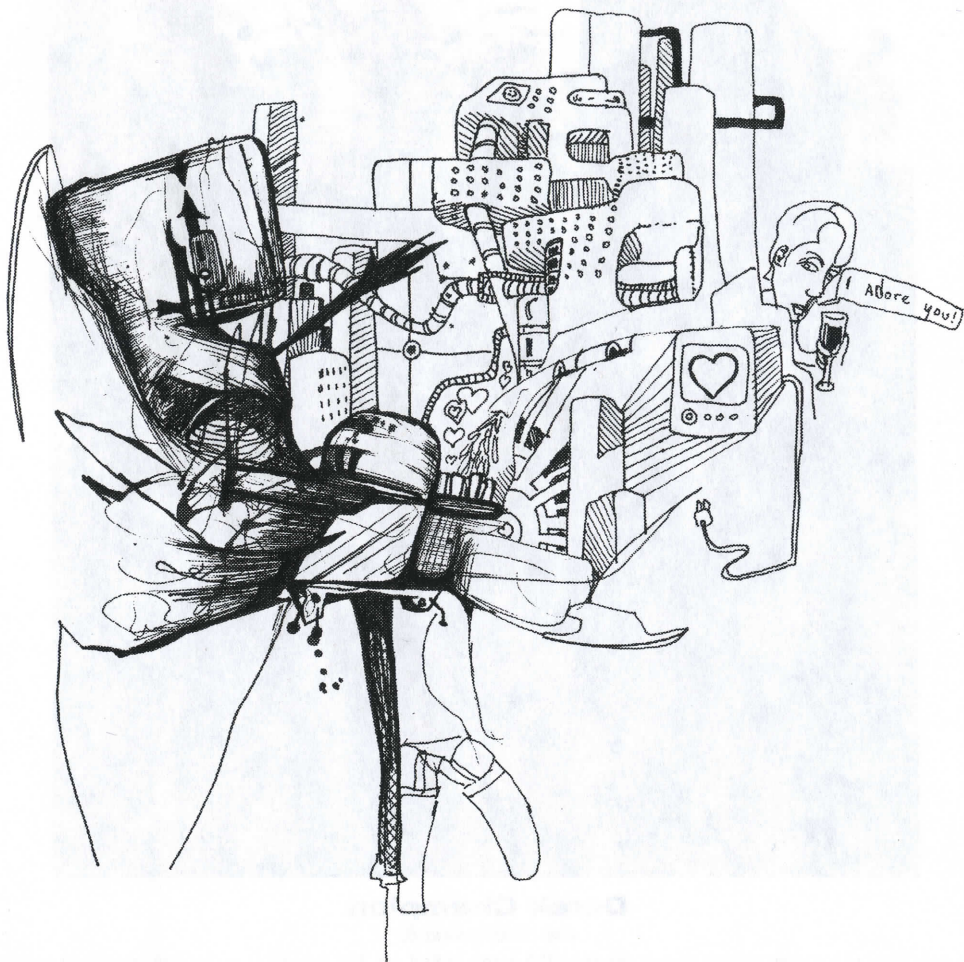

Christian Nicolay

(Live) (10:00) Vancouver, BC

It may be difficult to understand why I would change or modify the specific function of one thing by taking it apart or assembling it incongruously with something else. It is not understanding that I am searching for. Rather, these explorations are a means for ending up in a place I don't know how to get to through logical investigations.

Christian has performed his various sound projects in art galleries across Canada, as well as making unexpected noise in saloons, desolate highways, and street corners. Interested in a variety of media, Christian works with performance art, drawing, installation, sound recording and video - often simultaneously playing with notions of chance, spontaneity and humor.

The Inflect of Ventilation



Derek Champion

(Live) (20:00) Vancouver, BC

An improvised performance of sonic texture and noise that reacts against and fills the void of expectation using my collection of crazy value village toys and my assorted tech head digital gadgetry.

Derek Champion is a performance artist / avant noise musician from New Zealand, currently based in Vancouver, Canada. He has performed in venues throughout New Zealand, Canada and the USA, including the Knitting Factory in New York. The majority of his performance work has been in collaboration with performance artist Satina Saturnina; he was the mastermind behind the live/recorded music featured in these projects and often appeared as a Satina Droid. His most recent solo projects include participating in Western Front New Music's "Raw and Cooked" as well as the performance art and technology evening for New Forms Festival 2004.

Gloss



Patrick Valiquet

(Live) (10:00) Vancouver, BC

Live Manipulation / reorganization of computer / human generated sound. Patrick Valiquet is a composer / sound artist based in Vancouver

Holzkopf

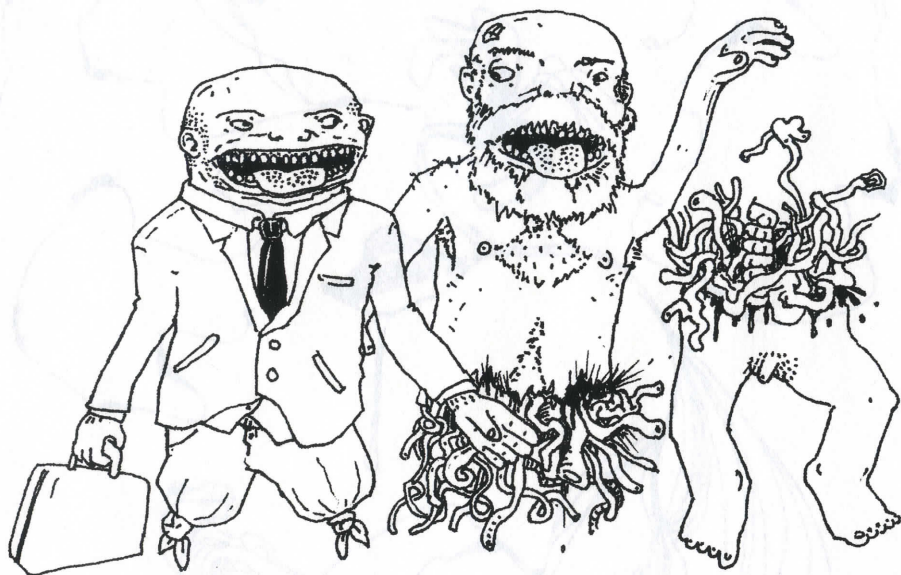

Holzkopf

(Live) (45.00) Saskatoon, SK

Holzkopf combines influences from the classics of the 20th century avant-garde, to underground hip-hop and drum and bass, to noise and sense numbing drones. Live performances are always unpredictable: like malfunctioning samplers spitting out raw data, noise that morphs into song structures only to break apart again.

Holzkopf is Saskatoon-based musician and audio artist Jake Hardy. He has released two full length CDs since 2001, and has supported them by touring throughout Canada and by contributing to various compilations around the globe. Full bio, reviews of work and sound samples are up at www.daintydeath.com

April 16 2005

The Safety Patrol

Interventional performance, Seattle USA

How do humans express their need for comfort and security in the face of inevitable death and impending doom? Never Fear! The Safety Patrol works to ensure the well being of all global citizens in an absurd representation of modern day neuroses as performed by the workers of the Department of Homeland Insecurity. Directed by Seattle performance artist Kristen Tsiatsios, The Safety Patrol weaves precise militaristic movement, witty dialogue and interactive madness in a show not to be missed.

Kristen Tsiatsios

Kristen Tsiatsios (performance artist/choreographer/installation artist) has been generating original performance in the Northwest region for the past nine years. Tsiatsios is co-founder and Chief Visionary of glassbones, a Seattle based performance company committed to the generation of cutting edge collaborative performance.

Also performed on this day is "Some Colour" see page 19 for description

Videos 3 A Bad Hair Day
Meesoo Lee

Quienes Son? (Who are they?)
Alex Stikich

Mollusc
Natalie Rich-Fernandez

The Architect
Rick Fisher

It Wouldn't Be Easy
Derek Brunen

Water, Paper, Scissors
Sylvain Verstricht

I Think We're Alone Now
Curtis Grahauer

Sixth Day Remix: Clone
Jowita Kepa

Two Dogs
Shaan Syed

Hydr(o)
Jason Arsenaunt

Sounds 3 Variations
Stephanie Loveless

stop fuckin around and
eat your dinner
reycle (wears) parts (guy)

It's Only Snow - It's Only Sunshine
vitaminsforyou

Digiroom
Per Samuelsson

Repeating Music
Eli Bornowsky

The Marble Factory #2
Tom Elliot & Angela Somerset

coin gutter

Catharsis: The transformative
and hypnotic nature of sound and
Frequency versus emotion and
physical atmosphere
Flatgrey



Meesoo Lee

(07:20) Vancouver, BC

Meesoo's parents are unimpressed with his "Canadian" hairstyle during a recent visit with them in Korea. This tape documents the bizarre half-hour contest-of-wills that will determine his future hairstyle.

Meesoo Lee started making short videos using a camcorder and 2 VCRs, inspired by the DIY ethos of zines, "lo-fi" music and underground cinema. He is old enough to remember when music videos were something new and exciting, before the proliferation of VCRs, camcorders and neighborhood video stores... One of his favorite music videos dates back to his elementary school years: "You Might Think" by The Cars. His work has been shown at the Western Front and Images Festival Toronto.

Quienes Son? (Who are they?)



Alex Stikich

(08.07) New York, USA

In October 1962, the world was at a standstill. In response to the failed invasion of Cuba by the United States, the Soviet Union began a buildup of offensive missiles on the island. The United States, in turn, imposed a blockade on Cuba and demanded that the Soviets dismantle their arms. After two tense weeks, the Soviets finally agreed, and in exchange, the Americans promised to never invade. This promise, however, never fully allayed Cuban fears of an attack...

"Quienes Son?" is an experimental short film that combines elements of documentary with fantasy to portray a surreal vision of Cuba. "Quienes Son?" uses an "extraterrestrial" metaphor to look at the testimonials regarding the appearance of "extraterrestrials" in the island. These sequences are woven together with the perspectives of the interviewer, and by the implied presence of the roaming intruder. Adding to the mixture are excerpts from Cuban radio that denounce the cultural and economical dominance of the United States, and a mysterious and spacey original score. While many films either romanticize Cuba's system, or critique the current regime, "Quienes Son?" aims to look at the lighter side of Cuba's fear of an invasion. Who are the aliens? Are they coming from outer space of Cape Canaveral? Today, Cuba is in a surreal zone, caught between the remnants of socialism and the harsh competitive reality of capitalism. Ever since the demise of the eastern bloc, Cuba has gone to great lengths to continue adhering to its ideology while being forced to concede some reforms. The ensuing economic and social "invasion" has and will continue to cast profound changes as the country eventually clashes with its post-Castro future. "Quienes Son?" is the first film in a series that will take unconventional views of an ever-more globalized world.

Alexander Stikich (filmmaker and photographer) grew up bouncing between Venezuela and Yugoslavia to eventually end up in New York. His work has been screened/exhibited worldwide in numerous festivals and venues including Sundance, the Worldwide Video Festival and The Brooklyn Museum of Art. Currently, he is working on various projects incorporating issues such as globalization, human rights, immigration and corruption. Alex is interested in combining elements of documentary together with a surreal overlay to create spontaneous and inspiring imagery.

Mollusc

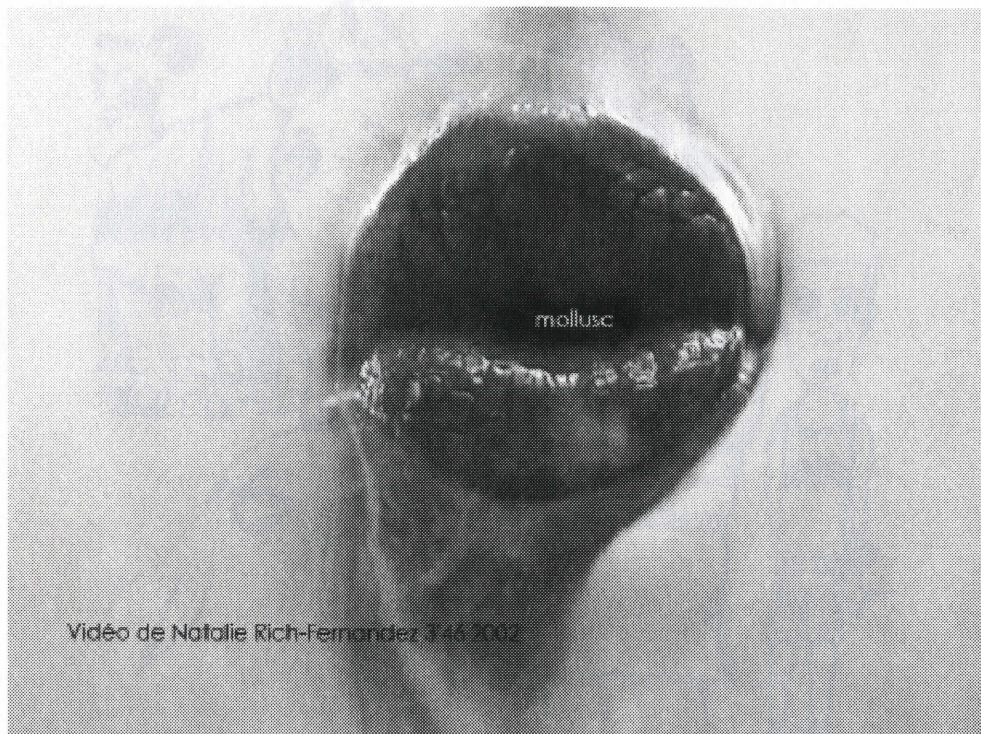

Natalie Rich-Fernandez

(03:46) France

There is no story told, it is generated by the accumulation of images, the work is one about the conscious, the subconscious, the animal side within us, the energies. In this video-film, I attribute the role of "Mollusc" to my mouth, allowing it to savour the delights of such liquids as milk, grenadine and mint. Instantly, it absorbs, spits out, and blows: the tongue jets out and licks the coloured substance. The world is an amalgam of underwater, sensual, sexual, aesthetic animal and vegetable. I go into great detail, in somewhat of an exhibitionist manner, displaying a very intimate part of the body : the lips, the tongue, the wrinkles, the hair and the skin forming part of the framework, all of which, bathed in an elegant coloured substance, suggests the humid and aquatic nature of the mollusc. The sound-track of the film is focused on the movements of the lips, on its internal and personal murmurs, and the sounds of the delicate and subtle little bubbles. The mouth comprises a cavity which forms the initial segment of the digestive tube. The tongue is an elongated, fleshy and mobile entity located in this cavity. The saliva is a clear and flowing liquid secreted by the salivary glands, and the mollusc is an aquatic invertebrate or a humid composition of a soft and spineless body. The three principal partners are the snail, the octopus, and the mussel.

Natalie Rich-Fernandez has been painting for a long time and she tackles video as one does in painting, it seems like a performance where she dresses all the elements which compose and create an image.

The Architect

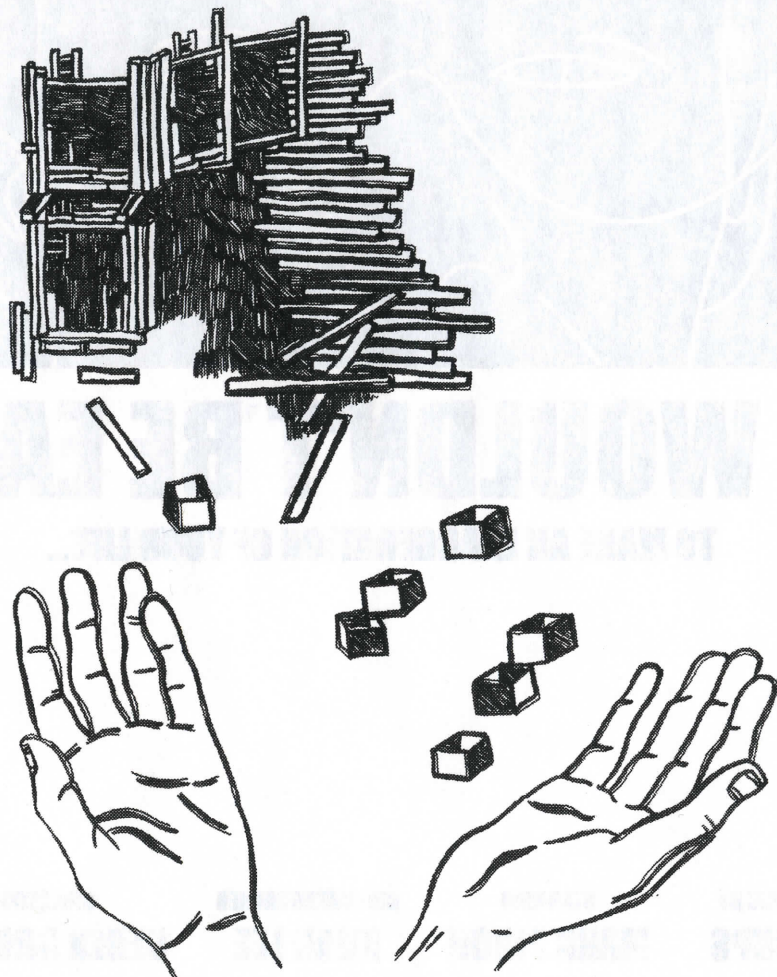

Rick Fisher

(03:40) Winnipeg, MB

The architect of ideology attempts to design a rationale to exist within the ambiguous territory located between "is" and "ought", and discovers that he has encountered an unresolvable dilemma.

Rick Fisher has been involved with video since the early 80's, and has worked as technical coordinator at several prairie art centres. His current art practice involves digital media and explorations into linear and nonlinear experimental narrative. He has completed one year of an MFA in Video.



IT WOULDN'T BE EASY

TO MAKE AN EXAGGERATION OF YOUR LIFE...

MUSIC BY
KRUPS

STARRING
MARK PIRON

CINEMATOGRAPHER
KHAN LEE

DIRECTOR
DEREK BRUNEN

INTERMISSION PRODUCTIONS

Derek Brunen

(04:00) Vancouver, BC

"It Wouldn't Be Easy" uses blindness as a metaphor for our relationship to fate. It encourages us to embrace the fateful events of our lives and to venture into the unknown even though this path is anything but easy.

Derek Brunen lives and works in Vancouver. He is a founding member of the artist collective Intermission. His work has been exhibited in Canada, Japan and the United States of America.

Water, Paper, Scissors

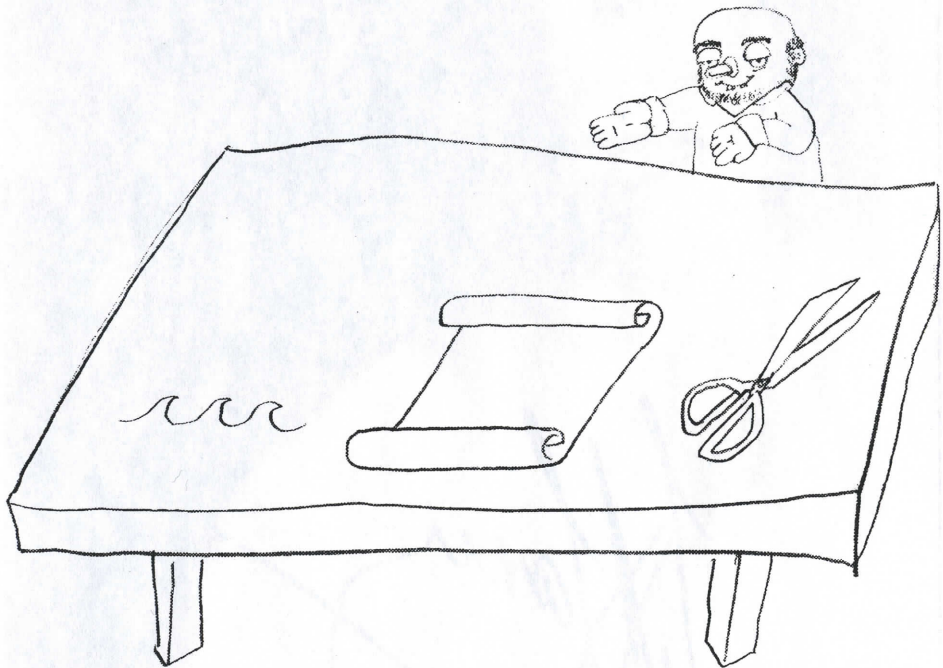

S.P.J. 2005

Sylvain Verstricht

(06:00) Montreal, QC

A young man attempts to demonstrate the frustrations of sexual orientation by using a glass of water, a porn magazine, and a pair of scissors in different combinations that are sometimes strange, sometimes humorous.

Sylvain Verstricht is an imaginer. He uses video and various other forms of writing to illustrate what he imagines so other people will understand him. Unfortunately, they usually only end up more confused.

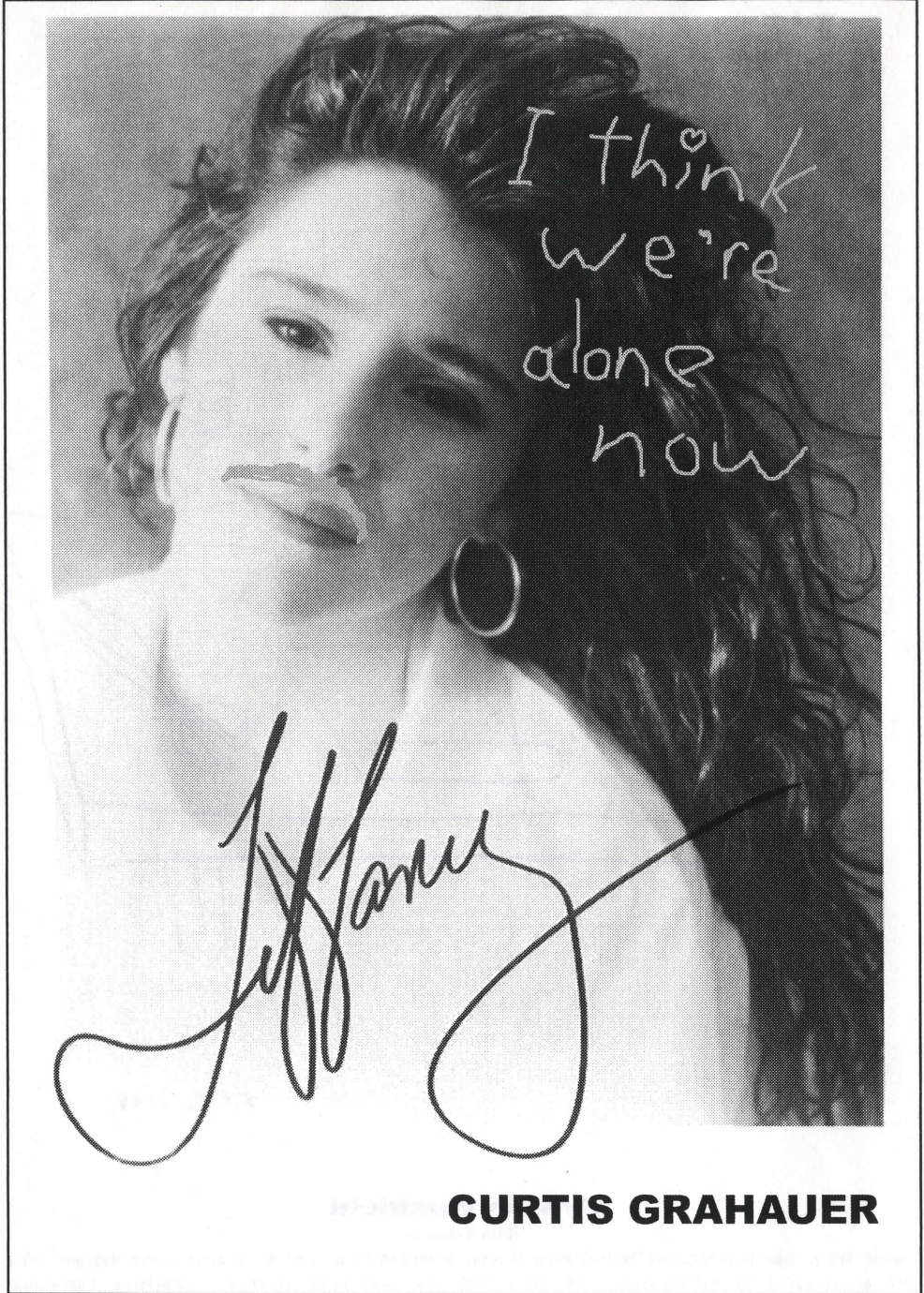

CURTIS GRAHAUER

(05:00), Vancouver, BC
A performance video of a guy kickin' it loose to Tiffany – a tribute, in dance form, to the mall performance queen using two 8-pound weights.

I have recently graduated from art school and have a smoldering passion for karaoke.



sixth day remix: clone 7

Jowita Kepa

(06:30) Toronto, ON

Death is no escape for a scientific experiment where life is revived endlessly. The digital image emulates this reproduction and the inevitable biological 'glitch'. This work was created using a single source for image and sound. Designed as a 'video art challenge,' to push skill and encourage individual creativity as a foil to the concept of the 'clone'. The current work is a unique interpretation, no longer resembling its original source.

Jowita Kepa is a visual artist based in Toronto. Following her Emerging Artist Award at the Images Festival 2001, she has received commissions from Images Festival, FameFame Media and the NFB. Her work has been screened in Toronto, Montreal, Vancouver, Chicago, Berlin, Paris, Hamburg, Novi Sad and Zurich.

Two Dogs



Shaan Syed

(02:24) Toronto, ON

Two Dogs is a hand-held classic animation showing two dogs in an ongoing and repeated dance of play and seduction.

Shaan Syed works primarily as a painter with occasional forays into animated film, sculpture and public intervention. He has shown his work in artist-run centers, commercial galleries and art fairs in Canada, Europe and the US. He currently lives and works in Toronto.

Hydr(o)



Jason Arsenault

(02:30) Montreal, QC

Hydr(o) is a digital drowning. This sequence-length shot is taken from video installation. The single-channel video exploits the feeling of anguish related to hydrophobia.

Jason Arsenault, member of Perte de Signal, is engaged primarily in creating digital video installations and single-channel videos that seek to question the spectator's role, reception, and experience of image and sound. He explores the notion of encounter that unfolds between his work and the spectator. His work has been screened in different festivals like the Microwave International Media Art Festival (Hong Kong) and the Hamburg International Short Film Festival (Germany). His video installations have also been presented in Quebec, New Brunswick and Mexico.



Variations



Stephanie Loveless

(pb) (3.07) Vancouver, BC

This short electroacoustic sound piece uses a fragment of a piano recording as its source material. This fragment is then stretched, processed, and otherwise explored, creating a slowly evolving soundscape that inhabits the space between sound and music, between object and abstraction.

Stephanie Loveless completed her BFA in Film Production with a minor in Electroacoustic Studies at Concordia University in Montreal. Her film, video and sound work focus on abstraction, manipulation, and exploration of the intrinsic qualities of her medium. Her work has screened in festivals across North America.

stop fuckin around and eat your dinner

one-eared Pillowguy with a stick through his head talks about Jesus and metaphysical truth

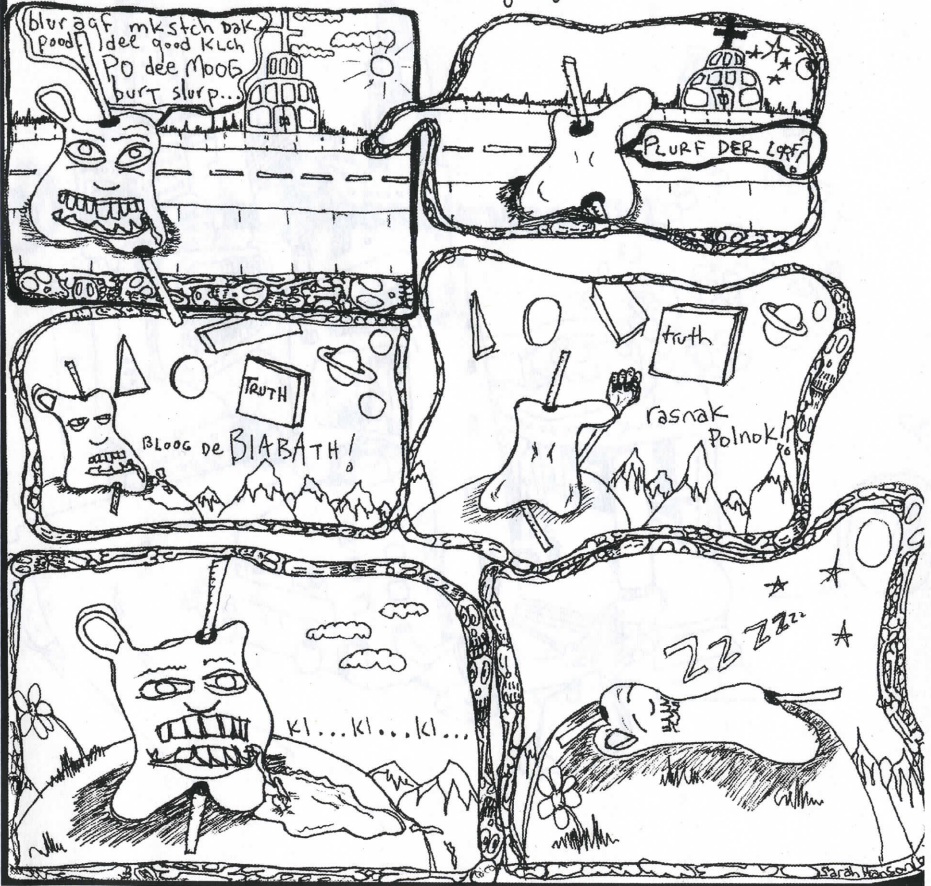

rezicle (wears) pants (guy)

(pb) (6:00) Vancouver, BC

dinner was terrible. dating sucks. a series of dots. Irezicle is at least 8' tall and she won't bend over for much. Pantsguy is a total pussy, but less so than you.

It's Only Snow – It's Only Sunshine

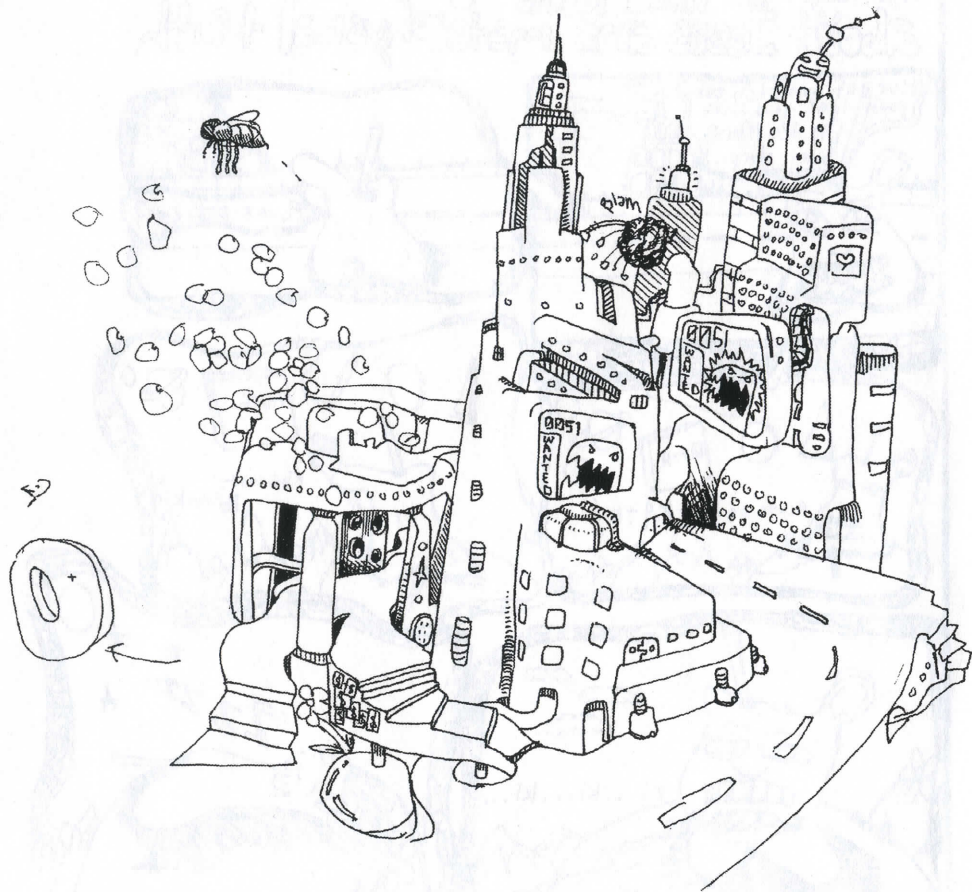

vitaminsforyou

(pb) (5.50) Toronto, ON

vitaminsforyou is internationally recognized for the way he effectively administers a double-dose of indie-pop and electronica, while keeping close to his experimental roots. vitaminsforyou carefully grazes the fine line between logic and emotion, juxtaposing all kinds of sound sources allowing the microscopic to give way to a provocative, compelling and gratifying melody.

vitaminsforyou, originally from Winnipeg, had a brief stint in Montreal, now in Toronto. vitaminsforyou has been developing sound and music for theatre, dance, film, video, animation, and prose across Canada, working with artists in a variety of genres, from electro-acoustic sound designers to some of Canada's darling pop practitioners.

Digiroom



Per Samuelsson

(Live pb) (8:14) Gavle, Sweden

Digiroom emulates the forces of people gathered in a room. The four walls of the "room" keep sounds together and group them into clusters which form new sound spectra. Other sounds try to break loose and want to break out from the four walls of the "room".

Per Samuelsson is a composer, sound artist, musician and sound engineer, with focus on experimental use of sounds and music. Music for live-performance, EAM-concerts and installations are often composed directly for surround sound. In 2003 Per was one of 5 composers to represent Sweden at the EAM festival at Bourges, France.

This Performance was made possible by Swedish Radio and the Embassy of Sweden

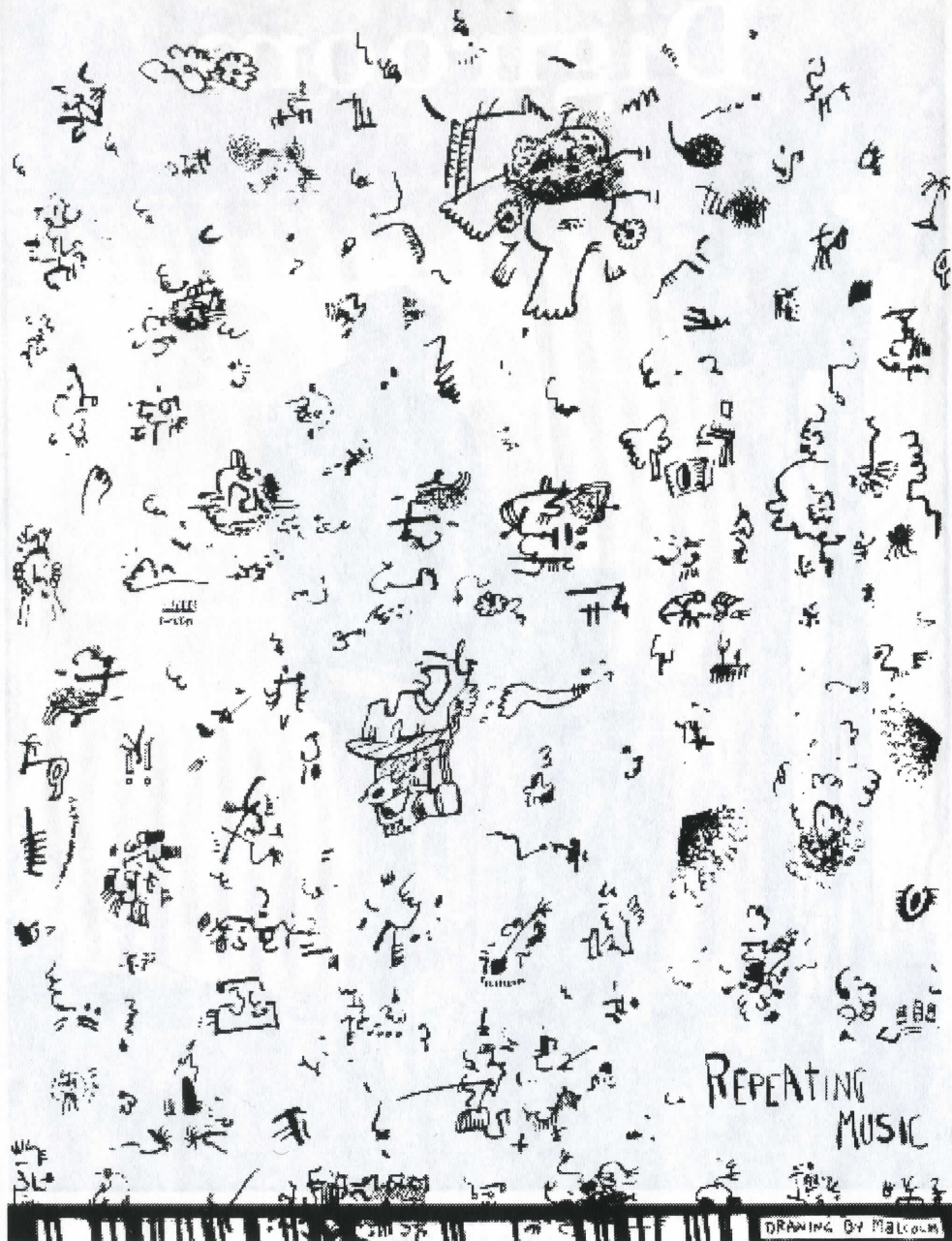

Eli Bornowsky

(pb) (10.00) Vancouver, BC

Repeating Music is a brief investigation into repetition and its relationship with monotony, boredom, sex, and the internal relationships of repeating patterns and there effects on the subject.

Eli Bornowsky maintains a studio practice of experimental trajectories in drawing, sound and performance, often exploring the relationship between drawing and experiments in sound and music while continually attempting to subvert and negate oppressive language systems.

The Marble Factory #2

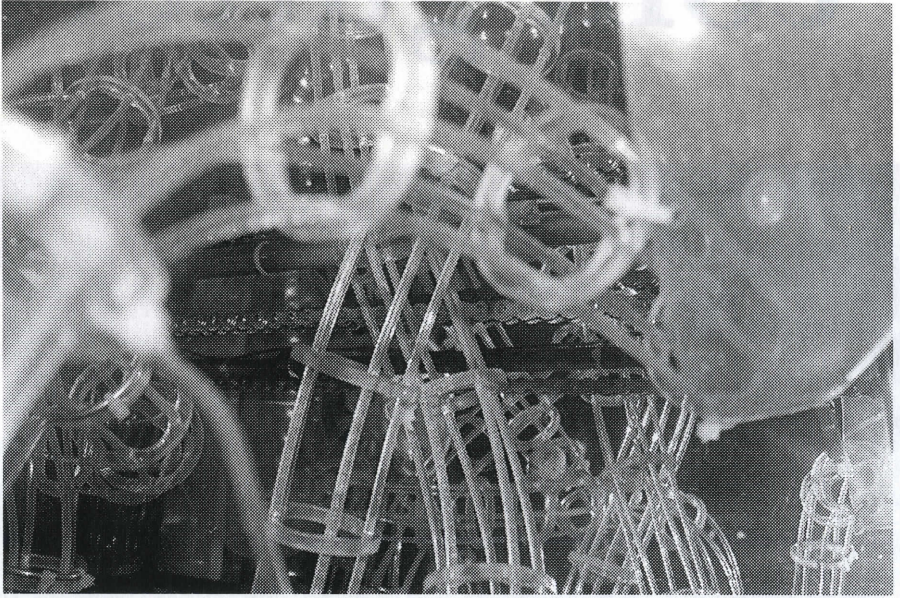

**1:20 a.m. working without headphones. we are reckless. sounds of one gigantic stapler after another.
dry floors creaking. movements above or below. a knock on the door. answer the door and explain.
we are collating enormous quantities of paper for a special event on saturday and you are invited.**

the marble factory: tom elliott and angela somerset

(Live) (16:00) Winnipeg, MB

We began this project shortly after reading of a factory that produced one million marbles each day while operated by only two workers. The idea of a marble factory became, for us, the idea of a continual possibility for making things - always transforming; both machines and their operators. We interact with material objects and processes, recording mechanical gestures with found and altered objects as a way of imagining the machines, considering how they are constructed, for what purpose, and how they behave. For public presentation we are interested in how our sounds and images might simultaneously alter and take on the physical and social resonance of their environment. This offers us the opportunity to respond to the characteristics of various sites and to re-imagine the use of these spaces as temporary marble factories.

Tom Elliott and Angela Somerset are interdisciplinary artists living in Winnipeg, Manitoba. They have been collaborating on artistic and curatorial projects, artist-run centre publications, etc., on and off for about 9 years. The Marble Factory is an audio project that they have been focussing on for the last 2 years.

coin gutter

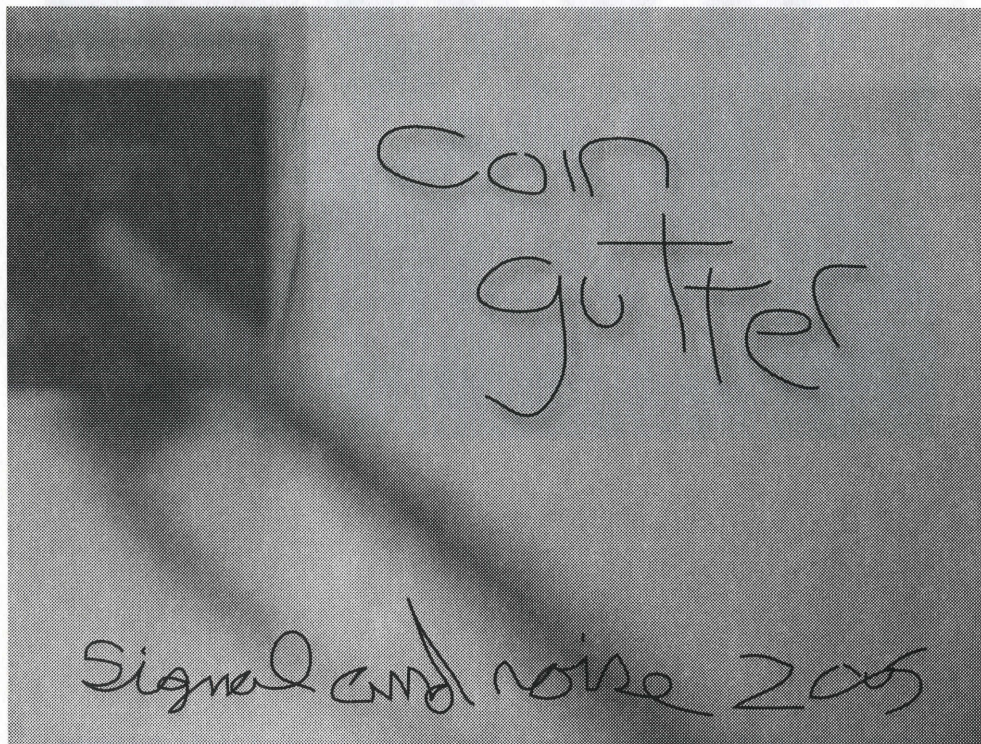

coin gutter

(Live) (30:00) Vancouver, BC

coin gutter is live improvised electronics and digital detritus for the onomatopoeically impaired.

coin gutter formed in 2000. coin gutter has done work for film/video/dance/theatre/performance and installation, but mostly for no reason. Unless you count the fame. Secretly, coin gutter is fame. coin gutter have 5 releases. visit www.coingutter.ca for more.



.Flatgrey.

Catharsis: the transformative and hypnotic nature of sound and frequency versus emotion and physical atmosphere.

**a solo
improvised
work for
six
mixers and
internal
feedback.**

Flatgrey

(30:00) Vancouver, BC

I work with internal feedback design manipulations and frequency looping techniques, using analog mixers with no input signals. This piece is a solo improvisation for six mixers attempting to address the subject matter mentioned in the title of the piece.

I have been playing in Vancouver's underground experimental noise and electronic hinterland for the last 4 years, and also in San Francisco, Edmonton, Barcelona, and Zurich.

April 17 2005

Introduction by PedalPlay, mutant offspring of PEDALPower, bring you footage of their ART/Bike project, "Velomutation". They will also be sharing some of their transformational methodology and notions on claiming new social spaces and reassessing the use of existing ones. They will be joined by the Margaret Charles Chopper Collective, a loose collective of freek bike riders. After the program you are invited to ride the freek bikes, challenge your balance, your dignity, and laugh your ass off.

Videos 4
easy rollin'
Marianne Bos & Hadas Levy

Don't Ride Shopping Carts
Graeme Patterson

Sounds 4
Beautiful Losers
Don Simmons

T.M.NelsonR.Y._B
Jean Routhier

Souns

The Phonographers Union

easy rollin'

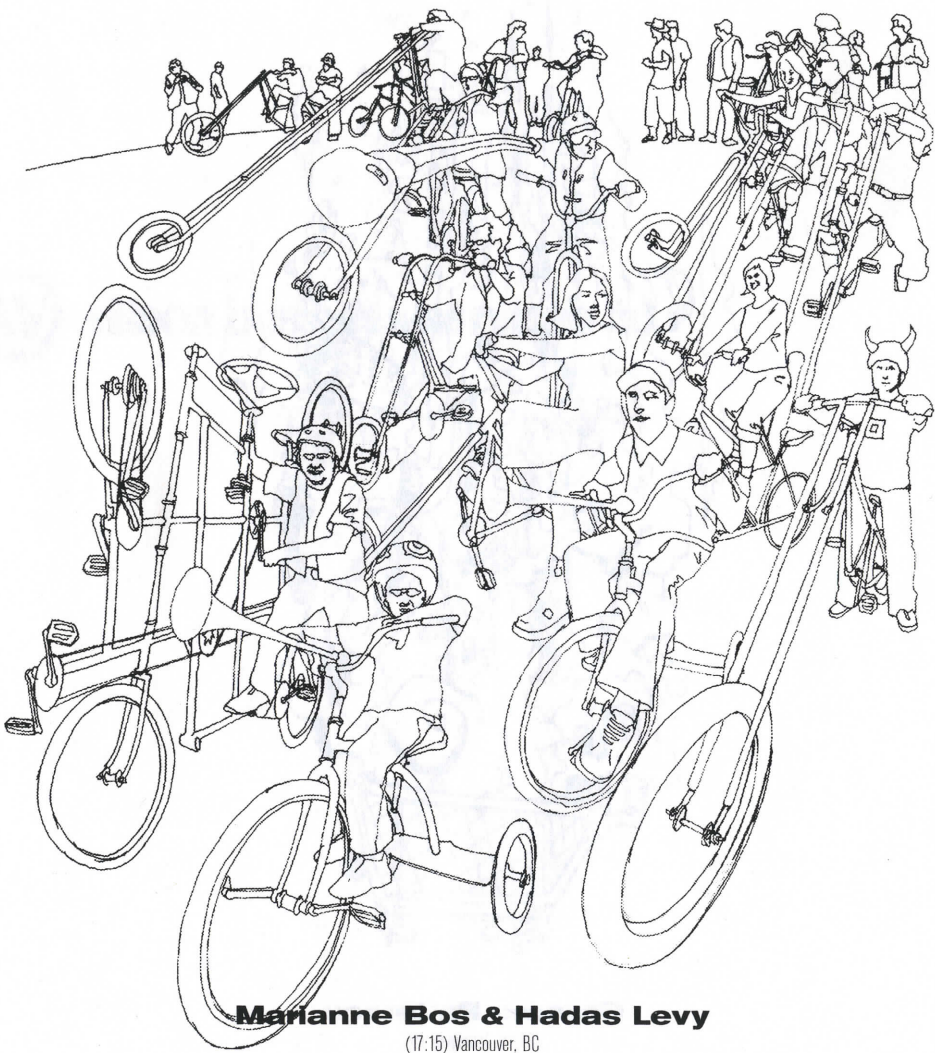

Marianne Bos & Hadas Levy

(17:15) Vancouver, BC

East Vancouver Chopper Mania! Need we say more - See it to believe it!!!

Marianne Bos & Hadas Levy both live and work within the Vancouver environs and surroundings. Amongst their many activist and interactivist activities, they find time to ride bicycles, drink coffee, and make their occasional video.

Don't Ride Shopping Carts

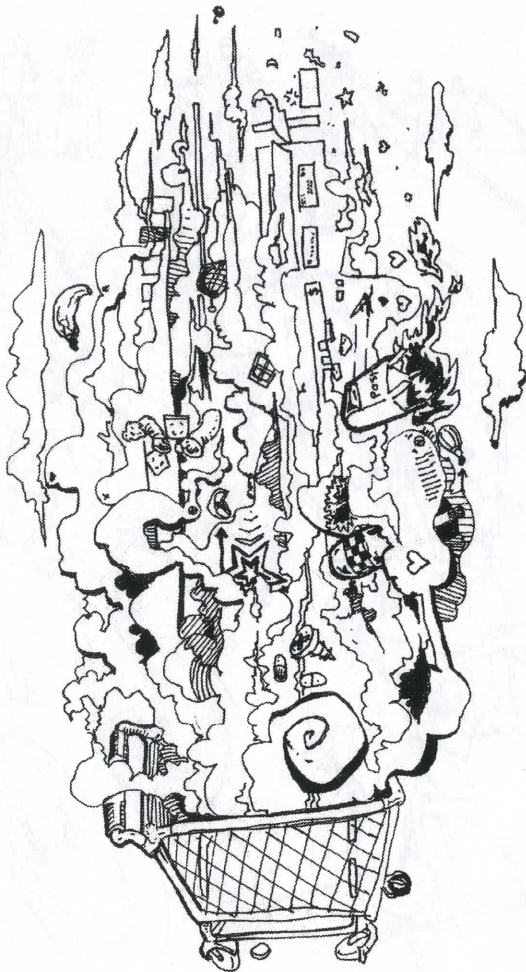

Graeme Patterson

(24:46) Winnipeg, MB

This stop-motion animation explores the life of a young man. He becomes consumed with dream worlds based on elements of his mundane reality. His obsession with understanding the relationship between his dream worlds and reality inspires him to follow a vision involving shopping carts, keyboards, rats and surreality.

Since the summer of 2001 Graeme has been working on "Don't Ride Shopping Carts" and developing his own process of digital stop-motion animation. Completed in December 2002, this is Graeme's first major production. As an interdisciplinary artist with a background in sculpture, painting, video, sound and music, stop-motion animation allows Graeme to incorporate many different forms of artistic expression into one form of media.

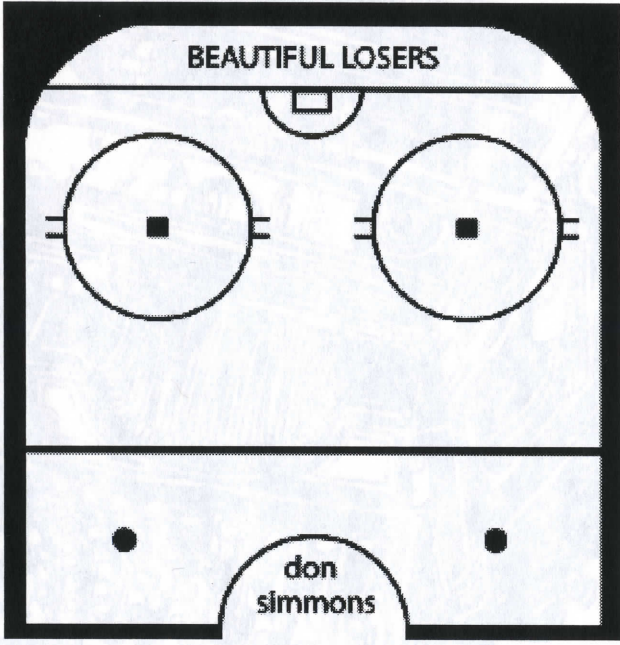

(pb) (80:00) Calgary, AB

The audio was sourced from a radio broadcast of the NHL's Stanley Cup Playoff Final between the Tampa Bay Lightning and the Calgary Flames in Game 7, June 6, 2004. Having a poor record during the season, the Flames were considered the underdog. With this recent rebirth of glory, the fans in city of Calgary ignited with enthusiasm causing mob mentality to rule the streets. At the end of the game, the city transformed itself into Cohen-esque 'beautiful losers'. On July 16, 2004, this audio was installed in a car parked at the Epcor Centre carpark, for the exhibition Bien Jouer. A valet assisted groups of three into the backseat of the car for their comfortable listening of the audio piece. It was remixed using MAX/MSP software at EMMEDIA, Calgary, Alberta.

Don Simmons is a conceptual artist based in Calgary, Alberta. Recently, he completed his MFA degree at the Nova Scotia College of Art and Design in Fine and Media Arts. In the past, he has studied art history in Italy while completing his diploma in Drawing and Painting at the Ontario College of Art and Design. Simmons has participated in exhibitions across Canada and the US, with forthcoming exhibitions at the Walter Phillips Gallery (Banff) curated by Jim Drobnick, the Western Front (Vancouver) curated by Victoria Singh & Velveeta Krisp, as well as the Truck Gallery and EMMEDIA in Calgary. Simmons' works usually take the form of robotics, electronics, audio, installation or performance. He is currently on faculty at the Alberta College of Art and Design in their Media Arts and Digital Technologies Department.

T.M:NelsonR.Y_B



Jean Routhier

(pb) (18.00) Vancouver, BC

"T.M:NelsonR.Y_B" is the audio component of an installation series entitled "une suite de temps-mort". Both contemporary and almost obsolete technologies are used to investigate space and reform the aural and visual traces originally witnessed to emphasise a new subjective narrative.

Jean Routhier is a Vancouver-based audio wrapper. His approach is similar to a store clerk, bagging everything into its sonic essence. Interested in the gaps and gasps of sounds conducive to the transmission of tales he sometimes hears in the ether. Routhier finds inspiration in everyday situations.

SOUNDS



dark light

Michael Red

(Live) (45:00) Vancouver, BC

The 'meaning' is for you to decide. The 'method' is largely improvised and intuitive. Using samplers, loopers, effects, mics, synth and various acoustic instruments, a live sound piece will be created from scratch. No pre-recorded sound will be used, just minimal presets and a video.

Michael Red is a dj, music producer and live p.a. artist, as well as an events promoter and organizer. Based out of Vancouver for the past seven years and active musically for over twelve, Michael's sound varies drastically from ragga-jungle and dancehall to downtempo and ambient. 'Sounds' is the name of Michael's live ambient/minimalist/experimental project, and 'environments' is the name used for events of similar flavor.

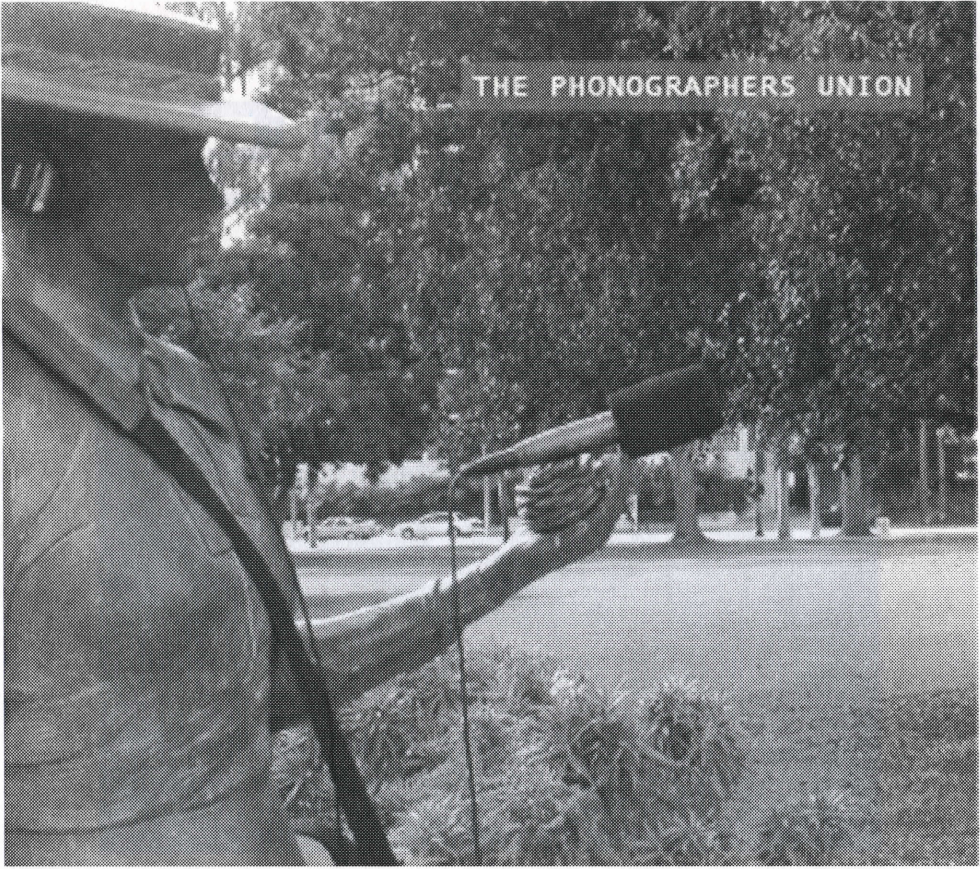

dark light

The Phonographers Union

(Live) (45:00) Seattle, WA

This work attends to the rhythms, signals, and vibrations of our world that often go unnoticed and unheard. Spared from the distractions of blinking lights, video projection, and other optical stimuli, audiences will have the opportunity to focus attention on the sounds that shape our world.

Through live, collective improvisation, the Seattle Phonographers Union conjures unusual and alluring soundscapes from unaltered field recordings made next door and around the world. Previous performances include Seattle's Center for Independent Media, Polestar Music Gallery, KEXP-FM, On The Boards, Northwest Film Forum and Portland's Contemporary Crafts Gallery.

Jury

Video 2005

Candie Tanaka is an interdisciplinary artist working with materials and methods that examine the tension between old technologies and new technologies and how this hybridity can result in unusual art projects. Archiving and the subversive collection of objects, images or sounds from public or institutional spaces are altered and placed back into the public realm as a new installation piece or artwork. These methodologies are gleaned from her personal experiences and explorations and inform her installation work by examining the structure of public and personal memory. Candie is a graduate of Emily Carr Institute of Art and Design's Intermedia program and is hoping one day to re-enter into educational institutions again only to somehow subvert the status quo. ☞

"In life, everybody has a role in different scenarios. Mine so far is to observe all these to discover the buried and blinded details of life and dreams or even unseen or unspoken ones. The privilege to show, whatever I have dreamt, seen and experienced."

Sebnem Koyuncu is a filmmaker/editeo. She started making films 8 years ago. Her films have been screened and awarded at various European and Canadian festivals. She completed her Digital Film Studies at AI-CDIS, Vancouver. She has directed and edited more than 10 short films and documentaries. Her works are from different genres, which speak to the diversity of sources and approaches. Her recent experimental video film "Boxy" was screened at explorASIAN 2004 (Vancouver) and the Portobello Film Festival in London, England. ☞

Ron Tran was born in Saigon, Vietnam on July 13, 1972 and came to Canada in 1987. He attended the Emily Carr Institute of Art and Design in Vancouver, BC, graduating in 2004. Over the past few years, Tran has produced work through various mediums: video, photography, drawing, sculpture, and performance. He also works collaboratively with the collective "Norma". Tran is currently living and working in Vancouver. ☞

Audio 2005

Sylvi MacCormac received Honourable Mention at Synthèse '99, the 29th International Electroacoustic Music Competition in Bourges, France, and produced the UTS'AM / WITNESS CD with various artists including Buffy Sainte-Marie, Barry Truax and the Squamish Eagle Song Dancers in 2004. MacCormac studied Electroacoustic and Soundscape composition with Barry Truax at SFU and works with voices, instruments and environmental sounds from her library and from the archives of the World Soundscape Project at SFU. As part of her degree Sylvi started the WHEELS Project (1997) working with the voices of people with (dis) abilities to create soundscapes and audio-portraits.
<http://www.sylvi.ca/na/da/bc> ☞

Mike Cantelon started drawing while living in a bus as a wee child. He drew and drew until, at age 9, he became obsessed with computer programming and drew less. In high school, circa 1990, he got bored with coding and started drawing again and experimenting with digital manipulation of photography. After graduating, Mike moved to Vancouver and taught himself how to write sample-based music using DOS software on a 486-PC. Working as a security guard and living in a shared house where a considerable amount of crack consumption went on, he released his first tracks via computer bulletin board systems (pre-Internet communication hubs), but found the geek world to be less than receptive to strange music. Eventually he found himself collaborating and organizing events with the Mediocre and Erisian Disco collectives. Mike currently releases and performs music under the name Bad Feng Shui and is playing around with video.
<http://ekim.neocodesoftware.com> ☞

Luke Meat is the Music Director of CiTR 101.9 FM in Vancouver (www.citr.ca). Since 2000, he has also been the host of the CiTR show "Anoize" (Wednesdays from 11:30am - 1 pm), which explores avant-garde, experimental, psychedelic, and noise music from Canada and around the world. He is a past contributor to and curator of CiTR's annual "24 Hours of Radio Art," and he is also a member of the Value Village People.
<http://members.shaw.ca/ecorpse/vp/wpm.htm> ☞

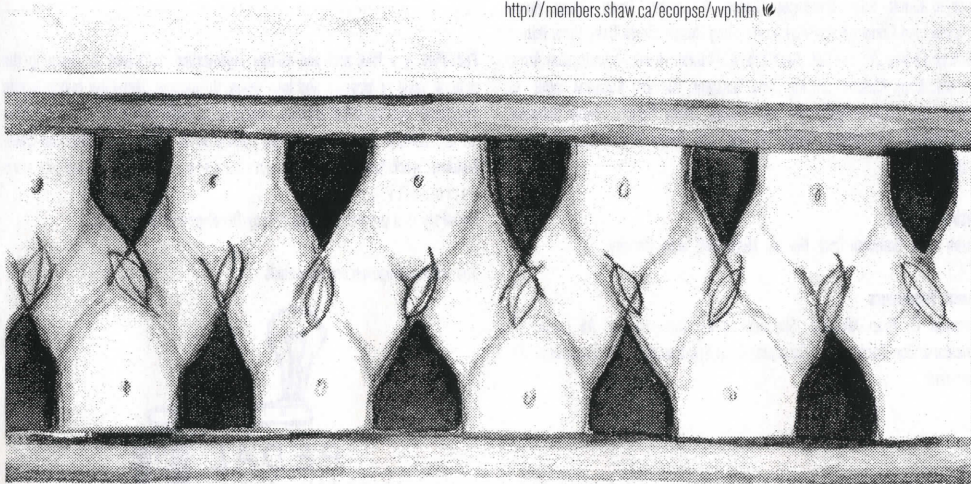

Thanks & Illustrators

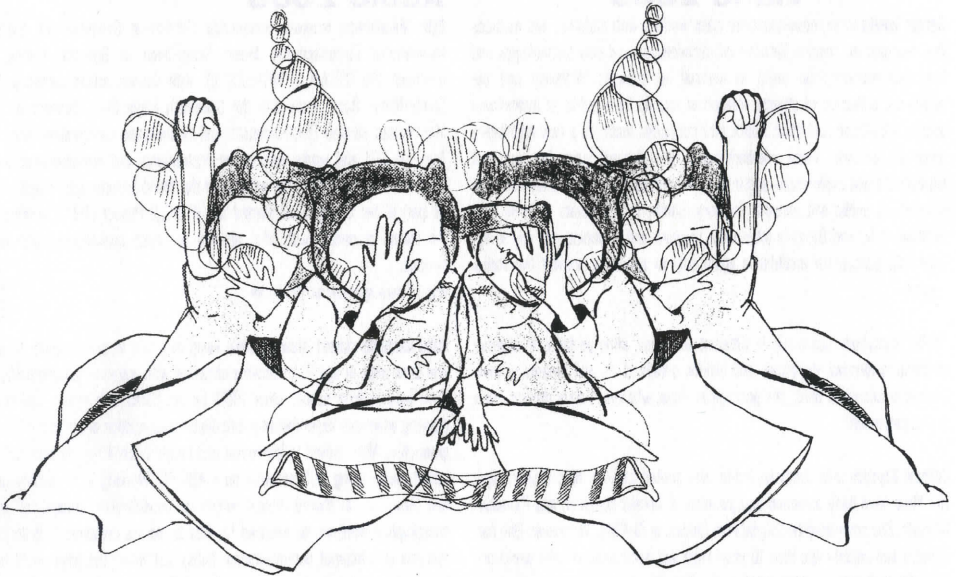

Thanks

Festival assistants: the Moch, Lyndsay Sung
Eciad festival assistants: Sita Kumar, Angela Gooliaff

Volunteer Coordinator: Jo Trotter

Event Coordinator: Jen Fisher

Tech Co: Emma Hendrix

Tech assistant: Stephanie Loveless

Internet Audio Coordinator / Sound God: Phil Thomson

Graphic Design: Rodney Sanches

Printing: Leo Pecchia: The Printing House Ltd.

Michael Barret, Gilles Boulenger, Gwenm A. Carsley, Trevor Chong, Aurore Cresson, Jim Cunningham, Mark Curry, Greg Cutten, Crista Dahl, Drew Dennis, Mathew Fithen, Zoe Gordini, Keith Higgins, Lauren Howes, Intermission Artists Society, Louis Klasson, Jin Ko, Jana Koszarek, Sebnem Koyuncu, Jane Lee, Hadas Levy, Heather McDermid, Jen Paches, Dinka Pignon, Derek Robinson, Scott Russel, Jim Sinclair, Sylvia "The Tea Lady", Donna Szoke, Rafael Tsuchida, Cease Wyss

Tech Volunteers

Helen Reed, Samonte Cruz, Heather McDermid, Mark Carvery

Event Volunteers

Deborah O, Ryan McCann, Shannon Harris, Nimi Langer, Ali Lohan, Liz Trueblood, Zoe Gordon, Ben Donogue, Yawn Spiritsquatch, Will Zuckowich, Zac Rothman

Drawings by

The Lions (page 23, 24, 25, 26, 27, 29) Eryn Rogers (page 37, 21) Robin Bougie (inside cover) Sarah Hanson (page 41, 51) Byron Dauncey (page 36) Liz Trueblood (page 7) Carly Haddon (page 65) Vincent Parker (page 35, 60, 38, 52, 60) Yuriko Iga (page 48) Serene Daud (page 31) Shayne Ehman (page 45) Jaime Auberger (page 4) Stephanie Lovely (page 11), Scott Malin (page 11, 43, 62) Andrew Pommier (page 6) Tiffany Monk (page 34, 47) Heather Harkins (page 22), Steve Calvert (page 8) Cindy Mochizuki (this page) Magnihild Winses (page 18) Malcolm Sutherland (page 40, 54) Seunggun Khan Lee (page 59)

PedalPlay is a bike arts and culture organization dedicated to elevating the cultural value of bicycles and bike riders. In practice, PedalPlay builds kinetic sculptures and theatrical vehicles, animates festivals, and creates and supports art and cultural production that has cycling as its theme. They also host bike-building workshops, and often create in a collaborative community context.

PedalPlay is a project of Pedal Energy Development Alternatives.

See www.pedalpower.org for details.

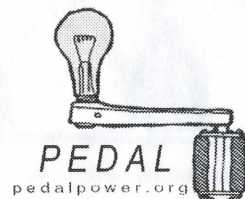

Festival Sponsors



Rocky Mountain Production Services

As our premiere sponsor, Rocky Mountain Production Services has provided a generous amount of equipment that places the quality of the Signal + Noise Festival at a superior level. We want to give a special thanks to Rocky Mountain Production Services for their significant contribution.



Matrix

Matrix is generously donating two prize packages of: 1 free weekend rental of a Sony HVR-Z1U High Definition DVD Camcorder. Included with each rental: a fluid head tripod, plenty of battery power and a Hi-Def tape.



Bike Doctor

The Bike Doctor has generously provided support for this year's Signal + Noise Festival by funding Program 4 of our Video screenings.



The Art of Loving at 5th and Burrard

We would like to extend a special thanks and acknowledgement to The Art of Loving for being the sole sponsor and financial contributor for this unique curated program. This special April 13th program at Pacific Cinéma-thèque of sex shorts from the L'Etrange Festival in Paris is presented as the carnal kick-off for the 2005 Signal + Noise Festival.

Terminal City

Terminal City

Our official Media Sponsor.



Pride UBC ~ The Resource Group for Gay, Lesbian, Bisexual and Transgendered People at the Alma Mater Society of UBC
For the support of local artists.

“Video In is a not for profit video production, exhibition and distribution centre. We are an evolving organization operated by and for artists and media / community activists.”

Since 1973, with the founding of the Satellite Video Exchange Society (SVES), Video In has grown into a vibrant artist-run centre with state of the art facilities and educational workshops.

We have production equipment, studio space, audio, video and new media post-production facilities, and during regular hours of operation, light-technical support is available to producers as they work.

April 14 - 17,
2005 

Video In Studios
Satellite Video Exchange Society
1965 Main Street, Vancouver, Canada 
+1.604.872.8337
www.videoin.ca
www.signalandnoise.ca

Video In Studios is grateful for the assistance of the Province of BC through the BC Arts Council and the BC Gaming Commission, the Canada Council for the Arts and the City of Vancouver. Supported by individual donations and by the labour and effort of artists, activists and cultural workers.



Terminal City

MATRIX



LETRANGE
FESTIVAL